

Rev.: 00

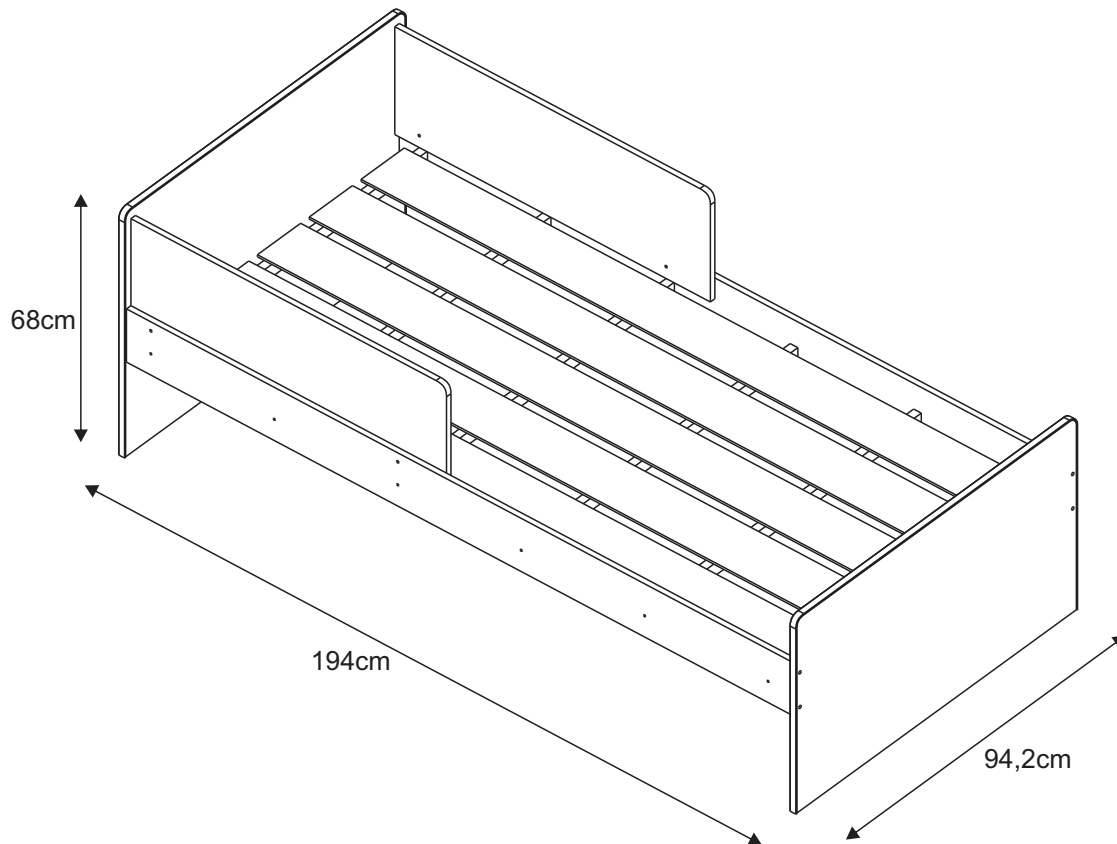

**CCM850**



1 Pessoa  
1 Persona  
1 Person

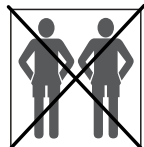

~~2 Pessoas~~  
~~2 Personas~~  
~~2 People~~



40  
MIN.  
Tempo de Montagem  
Tiempo de Armado  
Assembly Time

Abaixo as ferramentas, não fornecidas, mas necessárias para a montagem do produto.  
Abajo las herramientas, no suministradas, pero necesarias para el montaje del producto.  
Below are the tools, not supplied, but necessary for assembling the product.

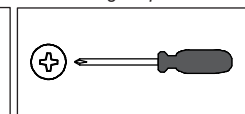
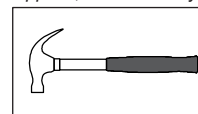

**Parabéns!**

**Você acaba de adquirir um produto com a qualidade Completa Móveis.**

**Recomendações**

- ≠ Os parafusos devem ser apertados periodicamente.
- ≠ Evitar batidas e o contato com objetos cortantes.

**Manutenção e Limpeza**

- ≠ Use um pano levemente umedecido com água, seguido de pano seco.
- ≠ Nunca utilize produtos químicos ou abrasivos.

**Alguma dúvida? Fale com a gente.**  
Completa Ind. de Móveis Ltda  
comercial@completamoveis.com.br

**Felicitaciones!**

**Usted acaba de adquirir un producto con la calidad Completa Móveis.**

**Recomendaciones**

- ≠ Los tornillos deben ser ajustados periódicamente.
- ≠ Evitar golpes y contacto con objetos cortantes.

**Manutención y Limpieza**

- ≠ Utilice un paño ligeramente humedecido con agua, seguido de un paño seco.
- ≠ Nunca utilice productos químicos o abrasivos.

**Alguna duda? Hable con nosotros.**  
Completa Ind. de Móveis Ltda  
comercial@completamoveis.com.br

**Congratulations!**

**You have just purchased a product with the quality of Completa Móveis.**

**Recommendations**

- ≠ Avoid impacts and contact with sharp objects.
- ≠ Screws must be tightened periodically.

**Maintenance And Cleaning**

- ≠ Never use chemical or abrasive products.
- ≠ Use a cloth lightly dampened with water, followed by a dry cloth.

*If you have any questions, please contact us:*  
Completa Ind. de Móveis Ltda  
comercial@completamoveis.com.br

**IDENTIFICAÇÃO DAS PEÇAS/IDENTIFICACIÓN DE LAS PIEZAS/IDENTIFICATION OF PARTS**

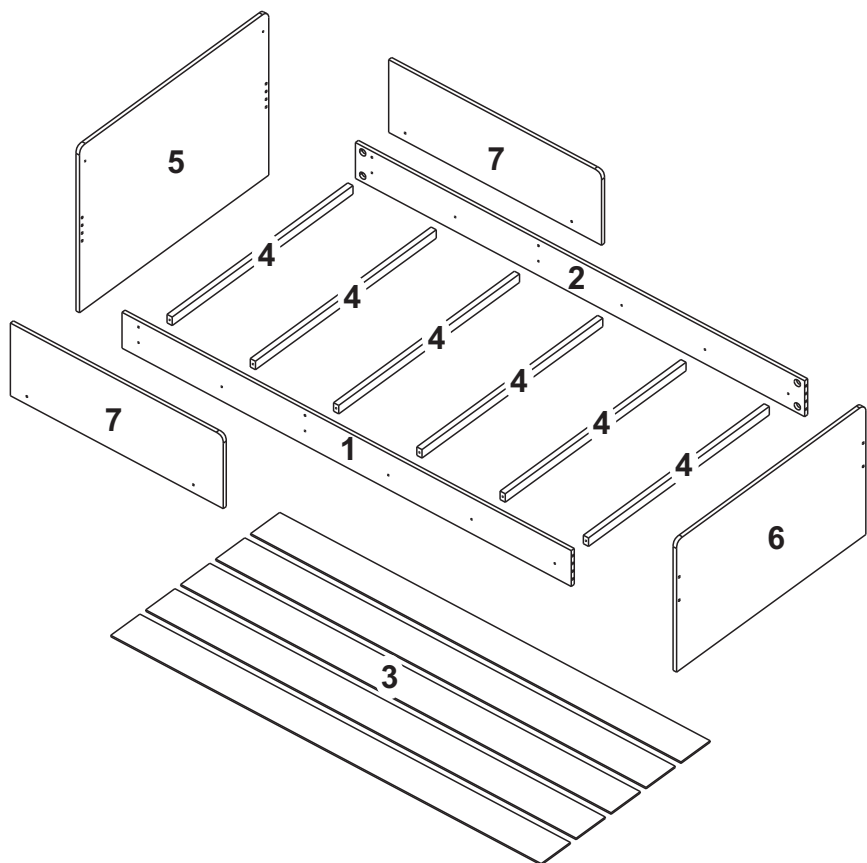

Nº	Descrição/Descripción/Parts description	Medidas/Dim. (mm)	Qtd. Cant./Qty	Vol.
1	Barra frontal/Travesaño Frontal/Front Crossbar	1910x148x15	01	01
2	Barra traseira/Travesaño trasero/Back Crossbar	1910x148x15	01	01
3	Lastro/Somier/Bed Base Slat	1830x145x6	05	01
4	Suporte de lastro/Soporte somier/Bed Base Support	900x35x22	06	02
5	Cabeceira/Cabecero/Headboard	942x680x15	01	02
6	Peseira/Piecera/Footboard	942x540x15	01	02
7	Protetor lateral/Protector lateral/Side Guard	905x300x15	02	02

**Peso máximo recomendado. Deve ser distribuído uniformemente.  
Peso máximo recomendado siendo este uniformemente distribuido.  
Maximum recommended weight must be evenly distributed.**

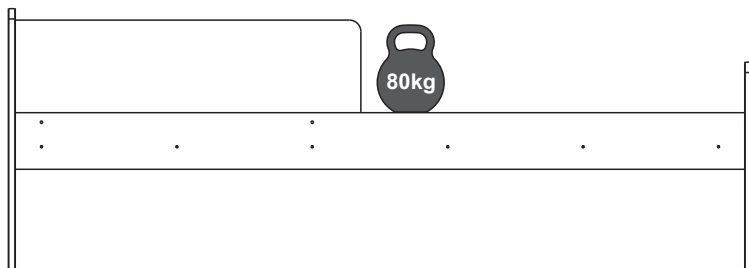









**ACESSÓRIOS/ACCESORIOS  
ACCESSORIES**

Antes de iniciar a montagem separe todos os acessórios. Em caso de dúvida no tamanho, utilize a régua no final da página.

Antes de empezar el armado, separe todos los accesorios. Si tienes dudas sobre el tamaño, utiliza la regla que se encuentra al final de la página.

Before starting assembly, separate all hardware components. If in doubt about size, use the measuring guide at the bottom of the page.

ID	Desenho/Dibujo/Hardware	Qtd. Cant./Qty
A	 Ø8x30 Cavilha/Tarugo/Wooden Dowel	08
B	 10x10 Prego/Clavo/Nails	04
C	 Ø4,5x45 Parafuso/Tornillo/Screw	14
D	 1/4x60 Parafuso/Tornillo/Screw	08
E	 Porca elíptica/Tuerca elíptica/Barrel Nut	08
F	 Bisnaga de cola/ Tubo de pegamento/Glue Tube	01
G	 Sapata/Apoyo plástico/Plastic Foot	04
H	 Ø3,5x25 Parafuso/Tornillo/Screw	30
I	 Parafuso de união/ Tornillo para unión/Connecting screw	04



# PRÉ-MONTAGEM / PRE ARMADO / PRE-ASSEMBLY

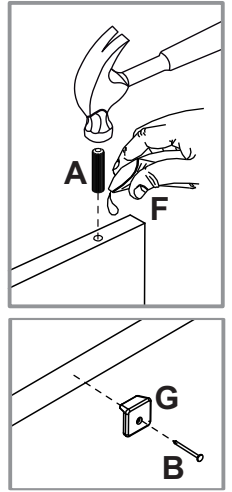
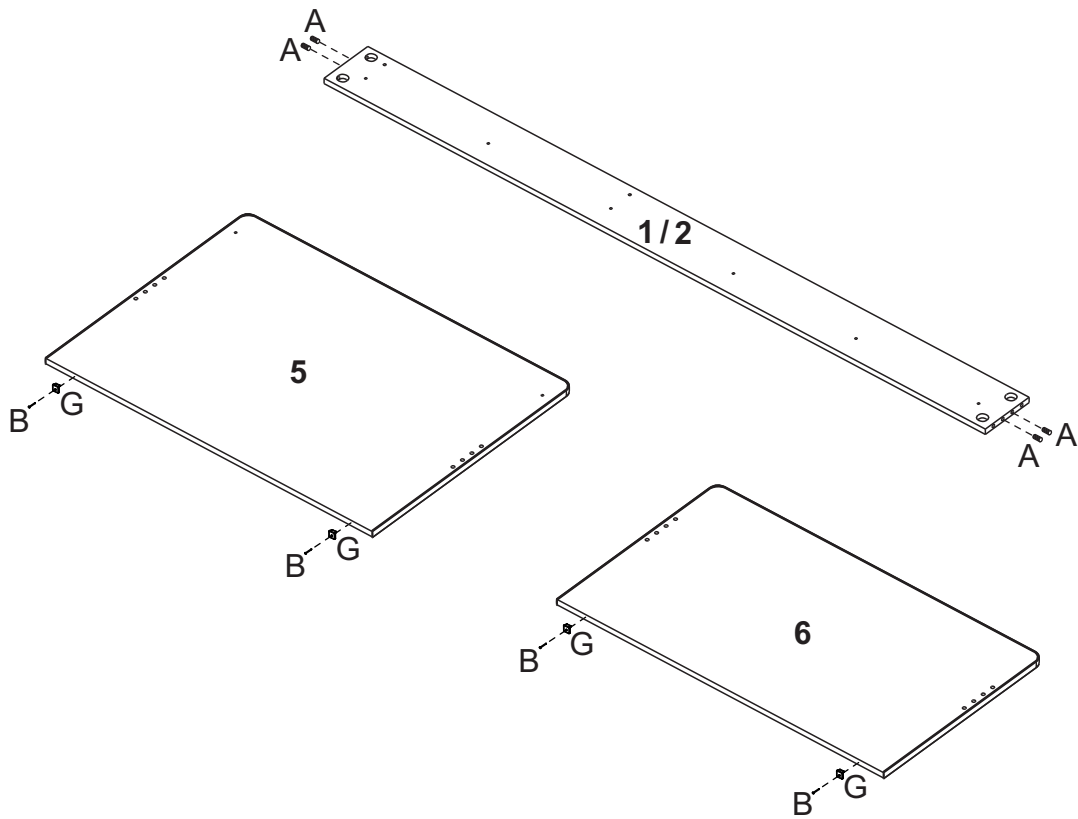

# MONTAGEM / ARMADO / ASSEMBLY

**Etapa 1/Paso 1/Step 1**

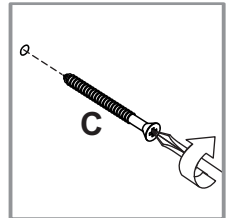
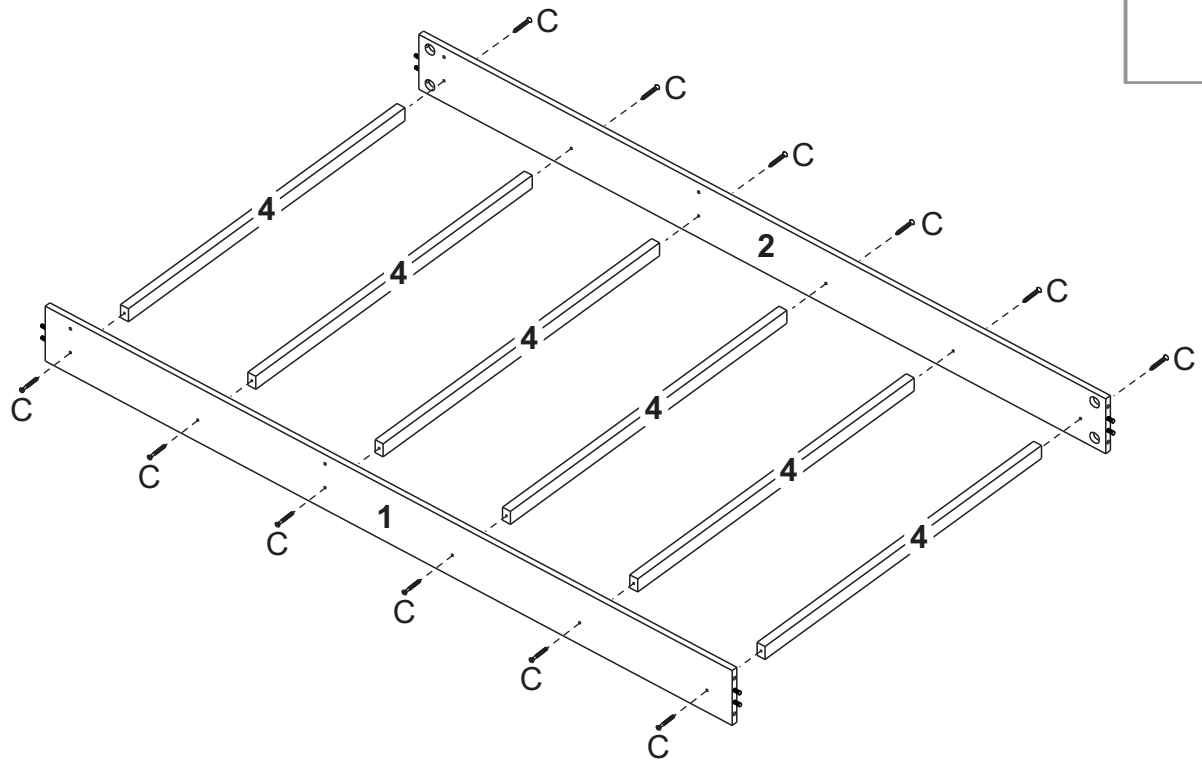

**Etapa 2/Paso 2/Step 2**

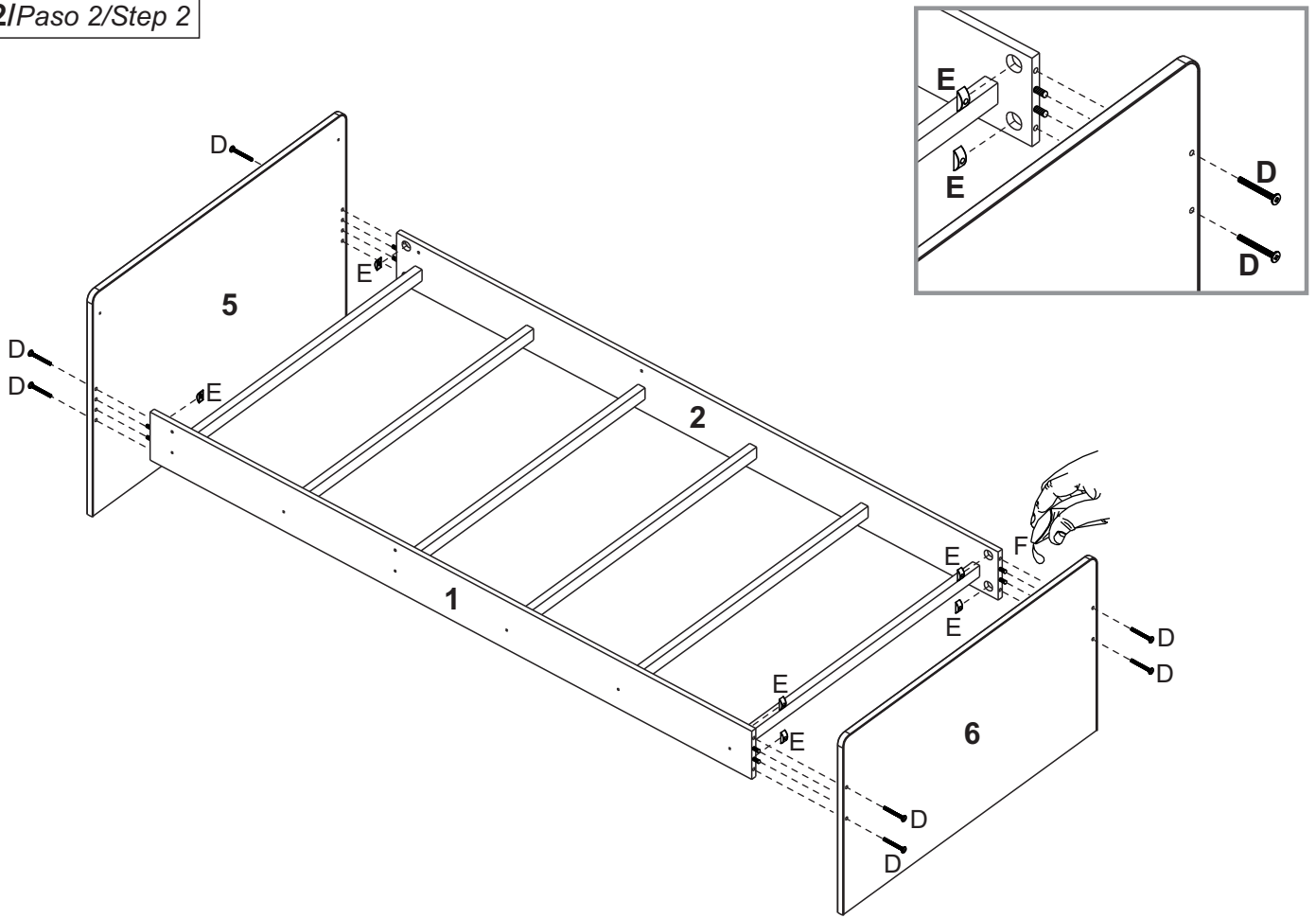

**Etapa 3/Paso 3/Step 3**

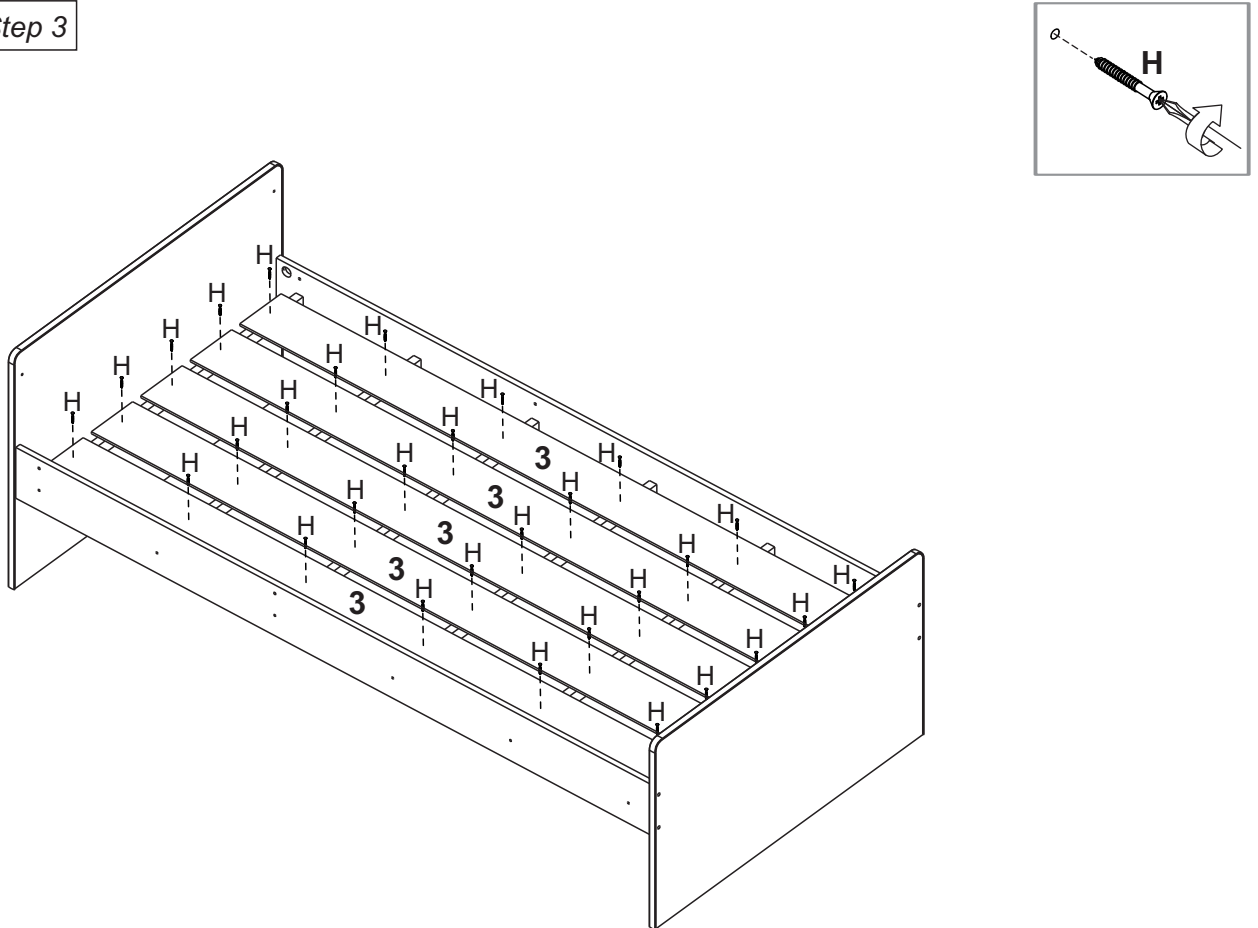

**Etapa 4/Paso 4/Step 4**

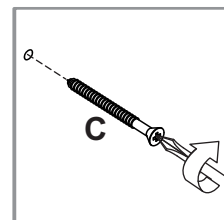
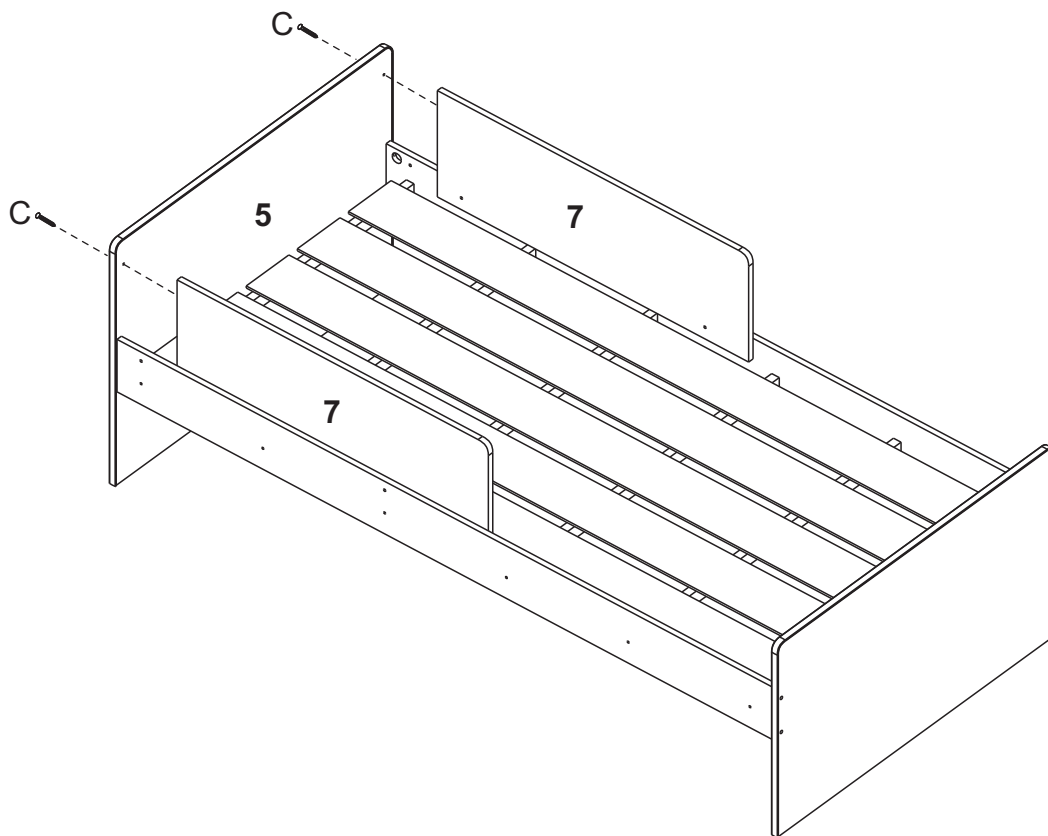

**Etapa 5/Paso 5/Step 5**

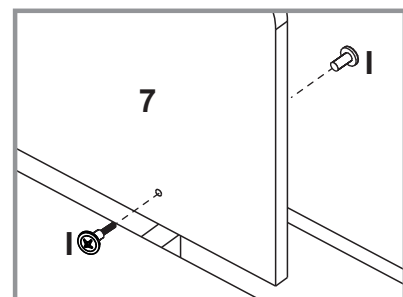
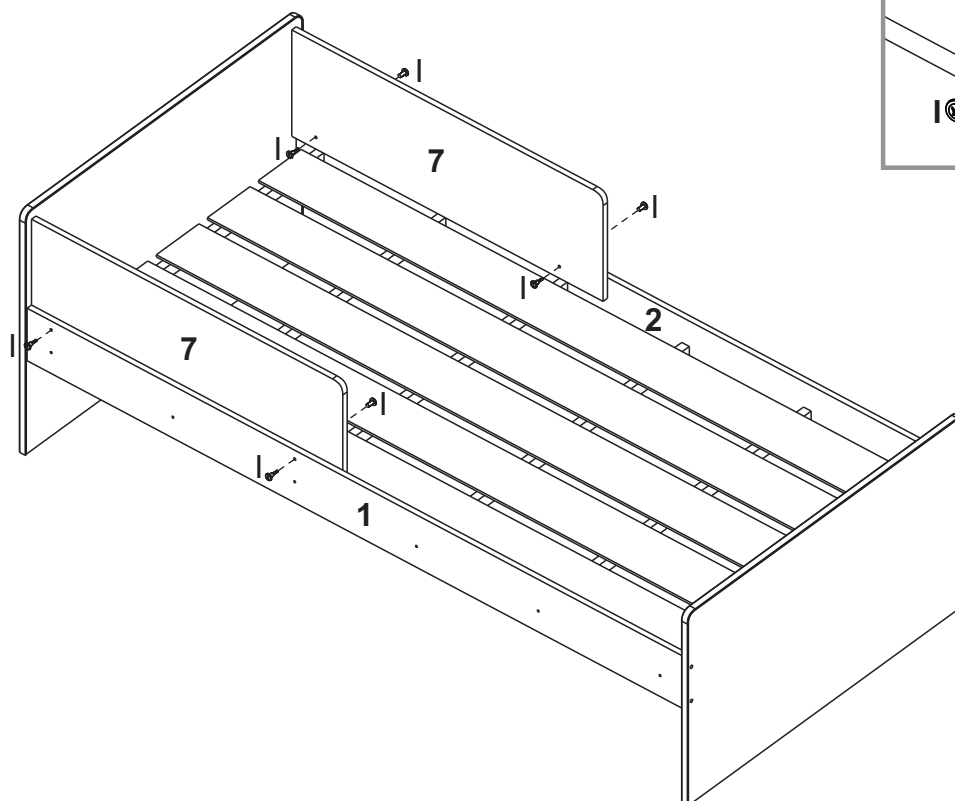

Rev.: 00

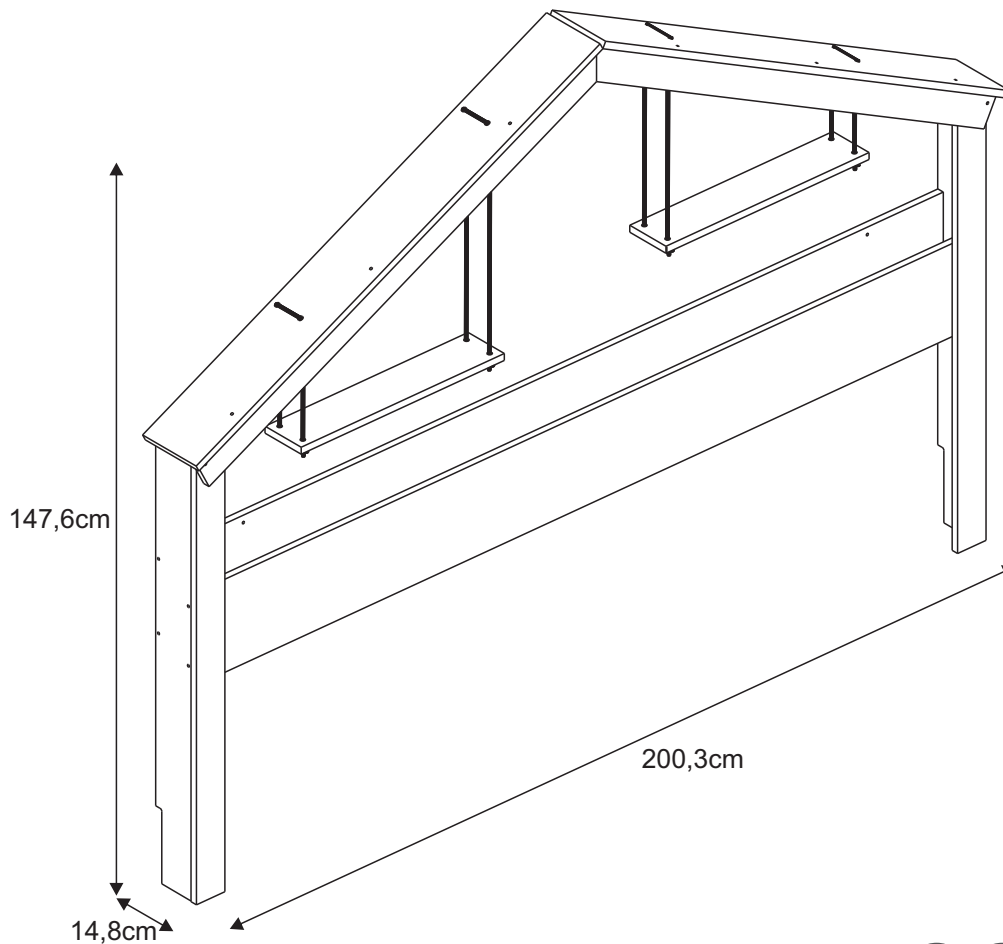

**CCM051**



1 Pessoa  
1 Persona  
1 Person

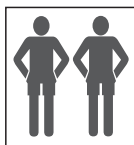

2 Pessoas  
2 Personas  
2 People



Tempo de Montagem  
Tiempo de Armado  
Assembly Time

Abaixo as ferramentas, não fornecidas, mas necessárias para a montagem do produto.  
Abajo las herramientas, no suministradas, pero necesarias para el montaje del producto.  
Below are the tools, not supplied, but necessary for assembling the product.

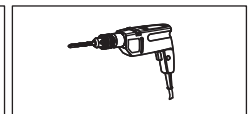
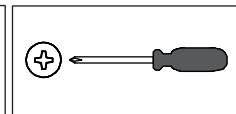
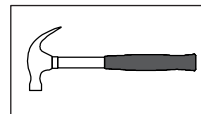

Furadeira com Broca de 8mm  
Taladro con broca de 8 mm  
Drill with 8 mm drill bit

**Parabéns!**

**Você acaba de adquirir um produto com a qualidade Completa Móveis.**

**Recomendações**

- ≠ Os parafusos devem ser apertados periodicamente.
- ≠ Evitar batidas e o contato com objetos cortantes.

**Manutenção e Limpeza**

- ≠ Use um pano levemente umedecido com água, seguido de pano seco.
- ≠ Nunca utilize produtos químicos ou abrasivos.

**Alguma dúvida? Fale com a gente.**  
Completa Ind. de Móveis Ltda  
comercial@completamoveis.com.br

**Felicitaciones!**

**Usted acaba de adquirir un producto con la calidad Completa Móveis.**

**Recomendaciones**

- ≠ Los tornillos deben ser ajustados periódicamente.
- ≠ Evitar golpes y contacto con objetos cortantes.

**Manutención y Limpieza**

- ≠ Utilice un paño ligeramente humedecido con agua, seguido de un paño seco.
- ≠ Nunca utilice productos químicos o abrasivos.

**Alguna duda? Hable con nosotros.**  
Completa Ind. de Móveis Ltda  
comercial@completamoveis.com.br

**Congratulations!**

**You have just purchased a product with the quality of Completa Móveis.**

**Recommendations**

- ≠ Avoid impacts and contact with sharp objects.
- ≠ Screws must be tightened periodically.

**Maintenance And Cleaning**

- ≠ Never use chemical or abrasive products.
- ≠ Use a cloth lightly dampened with water, followed by a dry cloth.

**If you have any questions, please contact us:**  
Completa Ind. de Móveis Ltda  
comercial@completamoveis.com.br

**IDENTIFICAÇÃO DAS PEÇAS/IDENTIFICACIÓN DE LAS PIEZAS/IDENTIFICATION OF PARTS**

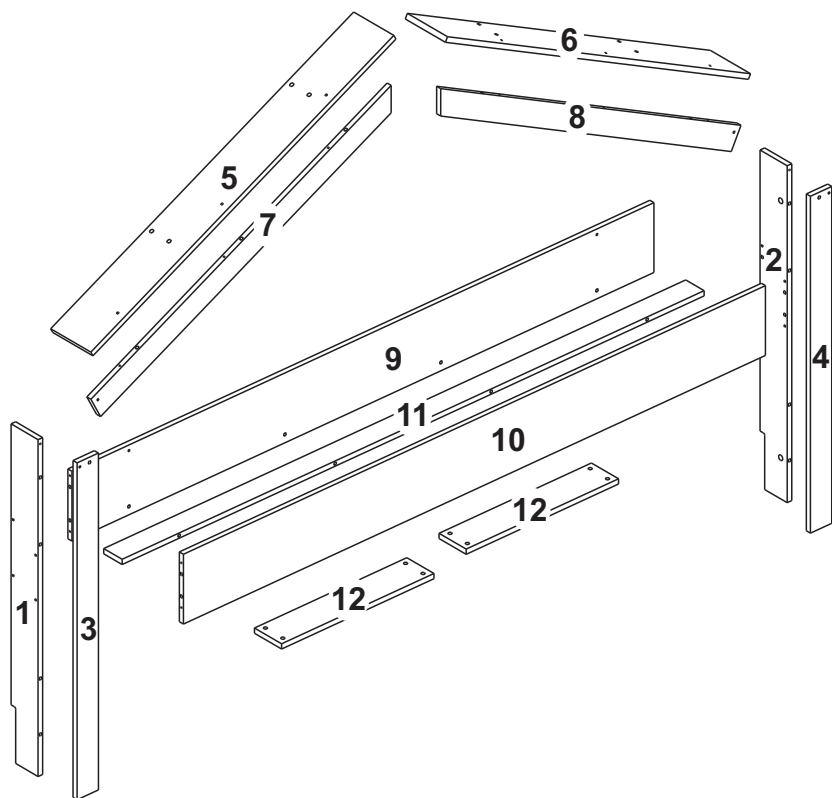

Nº	Descrição/Descripción/Parts description	Medidas/Dim. (mm)	Qtd. Cant./Qty	Vol.
1	Pé esquerdo/Pata izquierdo/Left foot	965x100x15	01	01
2	Pé direito/Pata derecho/Right foot	965x100x15	01	01
3	Pé frontal esquerdo/Pata delantera izquierdo/Front left foot	965x70x15	01	01
4	Pé frontal direito/Pata delantera derecho/Front right foot	965x70x15	01	01
5	Telhado esquerdo/Techo izquierdo/Left roof panel	1116x148x15	01	01
6	Telhado direito/Techo derecho/Right roof panel	1116x148x15	01	01
7	Trav. telhado esq./Travesaño techo izquierdo/Left roof crossbar	1106x70x15	01	01
8	Trav. telhado dir./Travesaño techo derecho/Right roof crossbar	1106x70x15	01	01
9	Trav. tras. livreiro/Travesaño trasero estantería/Back crossbar bookcase	1910x200x15	01	01
10	Trav. frontal livreiro/Travesaño delantero estantería/Front crossbar bookcase	1910x200x15	01	01
11	Base livreiro/Base/Base	1910x68x15	01	01
12	Prateleira/Repisa/Shelf	500x100x15	02	01

Peso máximo recomendado. Deve ser distribuído uniformemente.  
 Peso máximo recomendado siendo este uniformemente distribuido.  
 Maximum recommended weight must be evenly distributed.

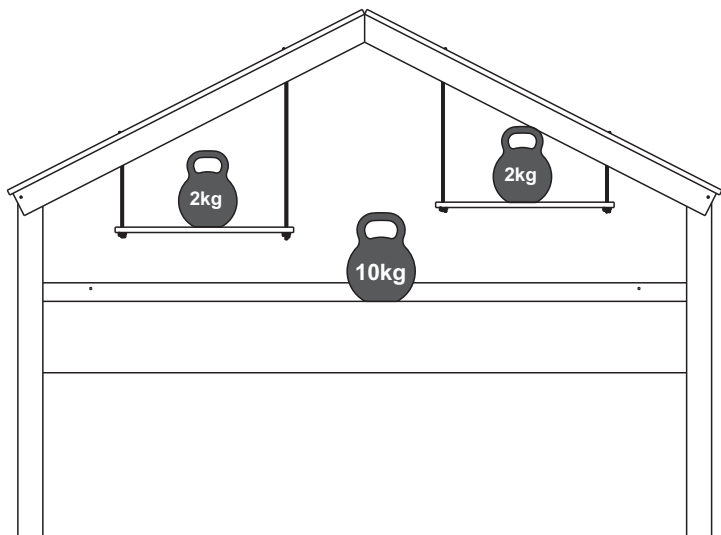

**ACESSÓRIOS/ACCESORIOS  
ACCESSORIES**

Antes de iniciar a montagem separe todos os acessórios. Em caso de dúvida no tamanho, utilize a régua no final da página.

Antes de empezar el armado, separe todos los accesorios. Si tienes dudas sobre el tamaño, utiliza la regla que se encuentra al final de la página.

Before starting assembly, separate all hardware components. If in doubt about size, use the measuring guide at the bottom of the page.

ID	Desenho/Dibujo/Hardware	Qtd. Cant./Qty
A	Ø8x30 Cavilha/Tarugo/Wooden Dowel	26
B	10x10 Prego/Clavo/Nails	04
C	Ø4,5x45 Parafuso/Tornillo/Screw	14
D	Ø5,0x60 Parafuso/Tornillo/Screw	04
E	Ø8x20 Cavilha/Tarugo/Wooden Dowel	02
F	 Bisnaga de cola/Tubo de pegamento/Glue Tube	01
G	 Sapata/Zapata/Plastic foot	04
H	Ø5,0x45 Parafuso/Tornillo/Screw	02
I	Ø3,5x14 Parafuso/Tornillo/Screw	12
J	8mm Buchas/Tacos para Tornillo/Wall plug	04
K	 Haste minifix/Tornillo minifix/Cam Bolt	04
L	 Tambor minifix/Tambor minifix/Cam Lock	04
M	 Cantoneira/Pieza L/L-Bracket	02
N	 Capa/Cubierta/Cover	02
O	 Chapa metálica/Chapa metálica/Metal piece	01
P	 Cantoneira metálica/Pieza L metálica/ Metal corner bracket	02
Q	1500mm Corda/Cuerda/Rope	04
R	 Tapa furo/Tapa agujero/Hole cover	24



# PRÉ-MONTAGEM / PRE ARMADO / PRE-ASSEMBLY

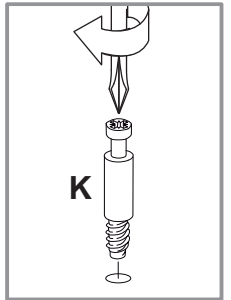
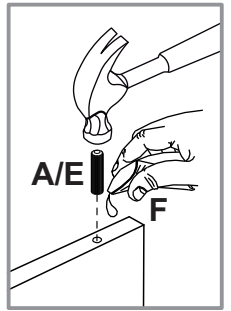
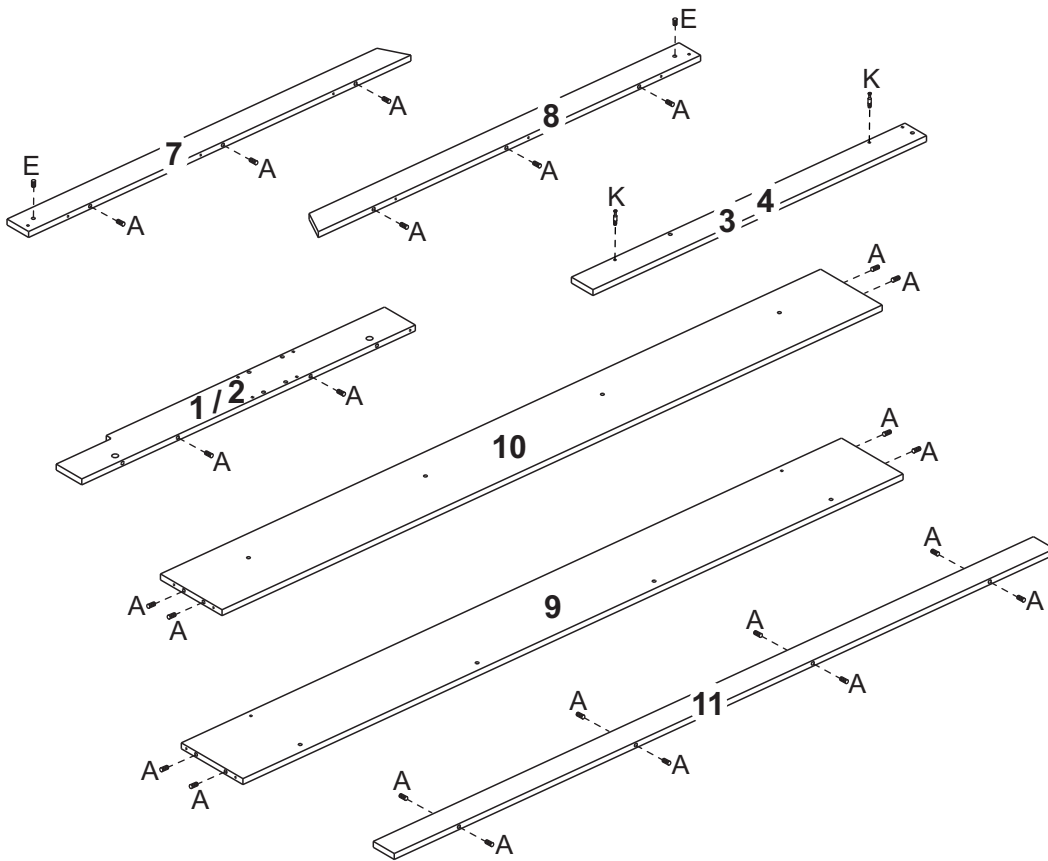

# MONTAGEM / ARMADO / ASSEMBLY

**Etapa 1/Paso 1/Step 1**

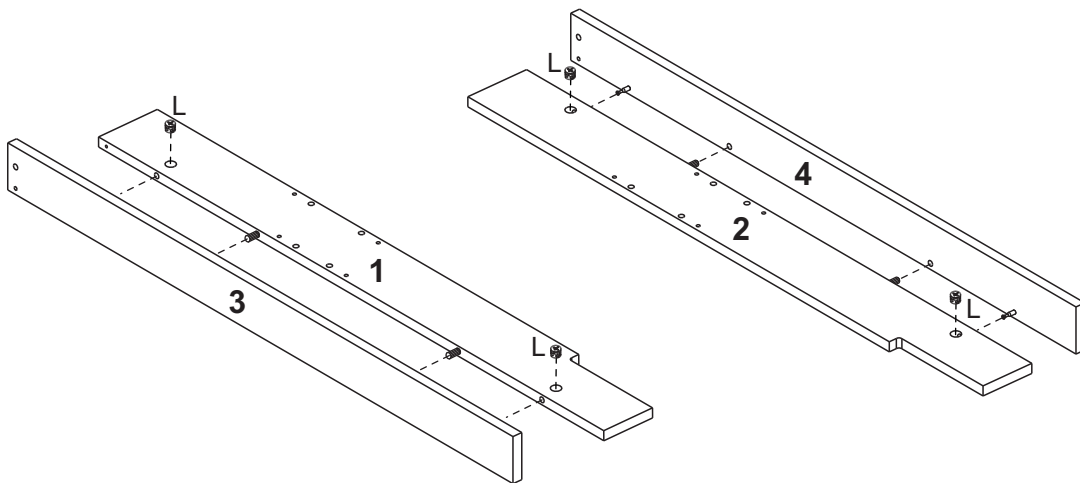
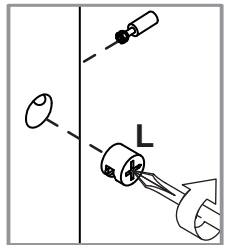

**Etapa 2/Paso 2/Step 2**

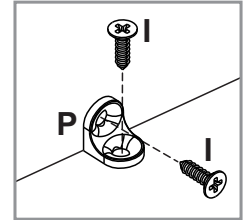
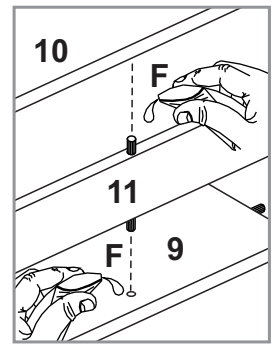
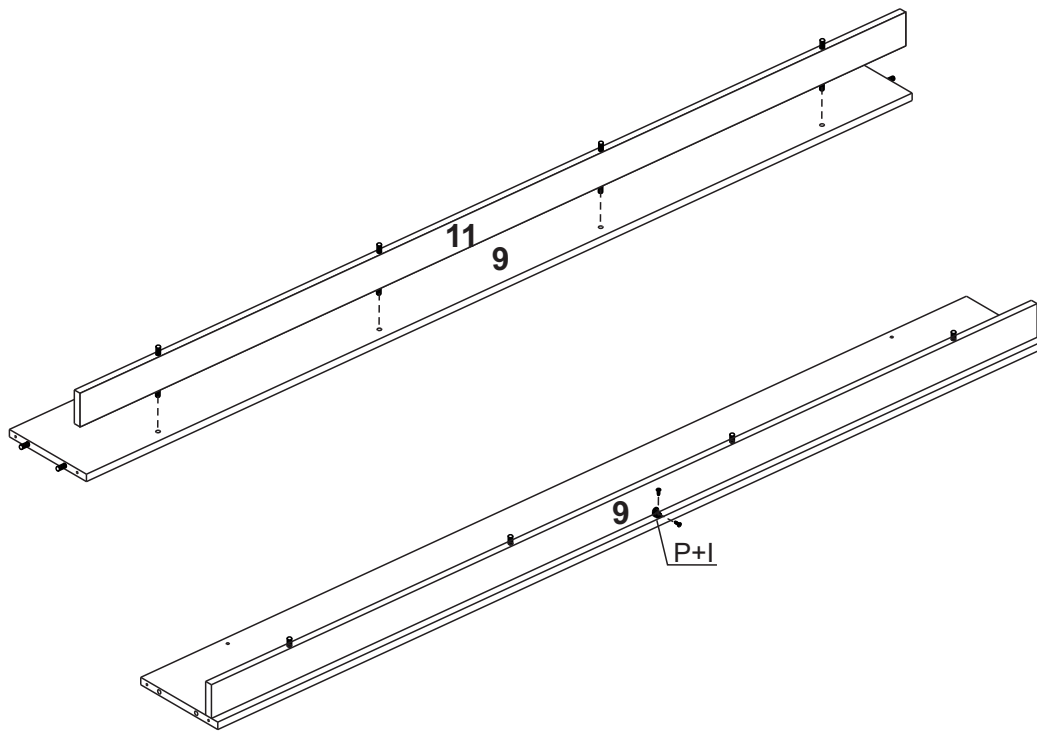

**Etapa 3/Paso 3/Step 3**

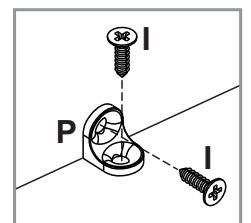
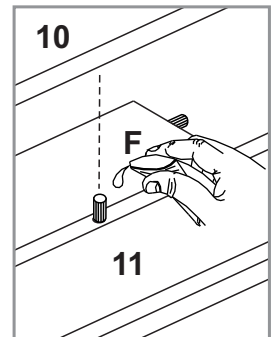
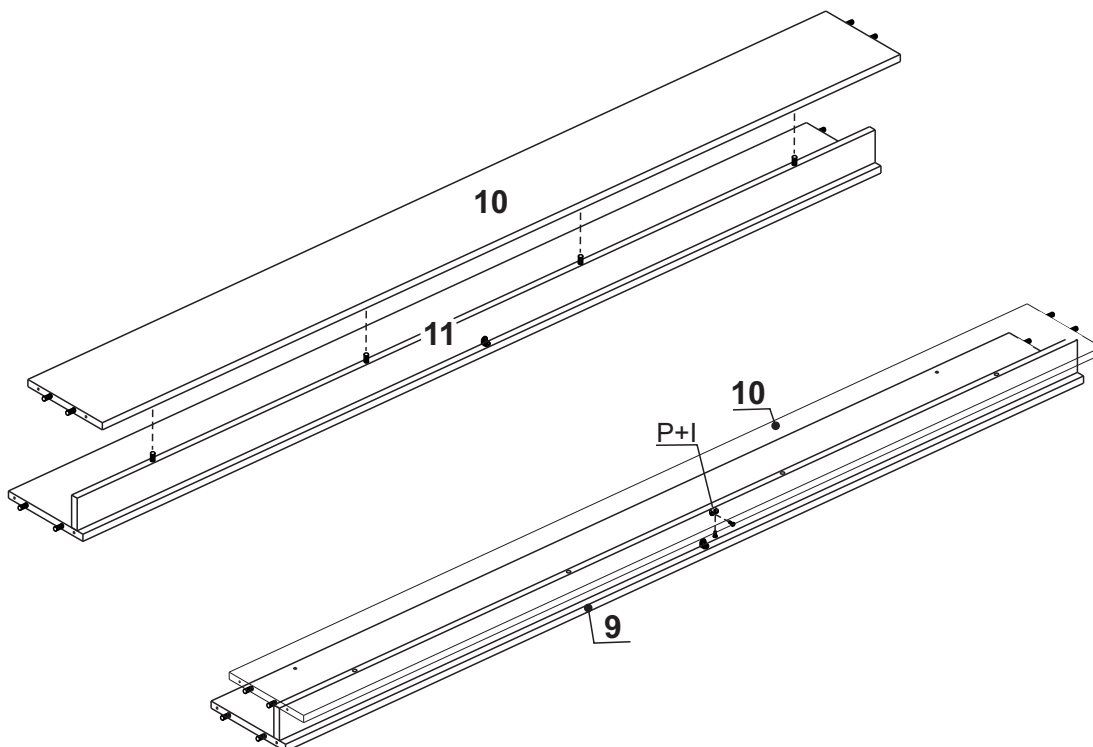

**Etapa 4/Paso 4/Step 4**

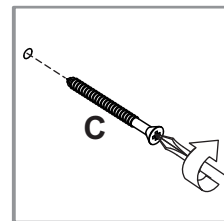
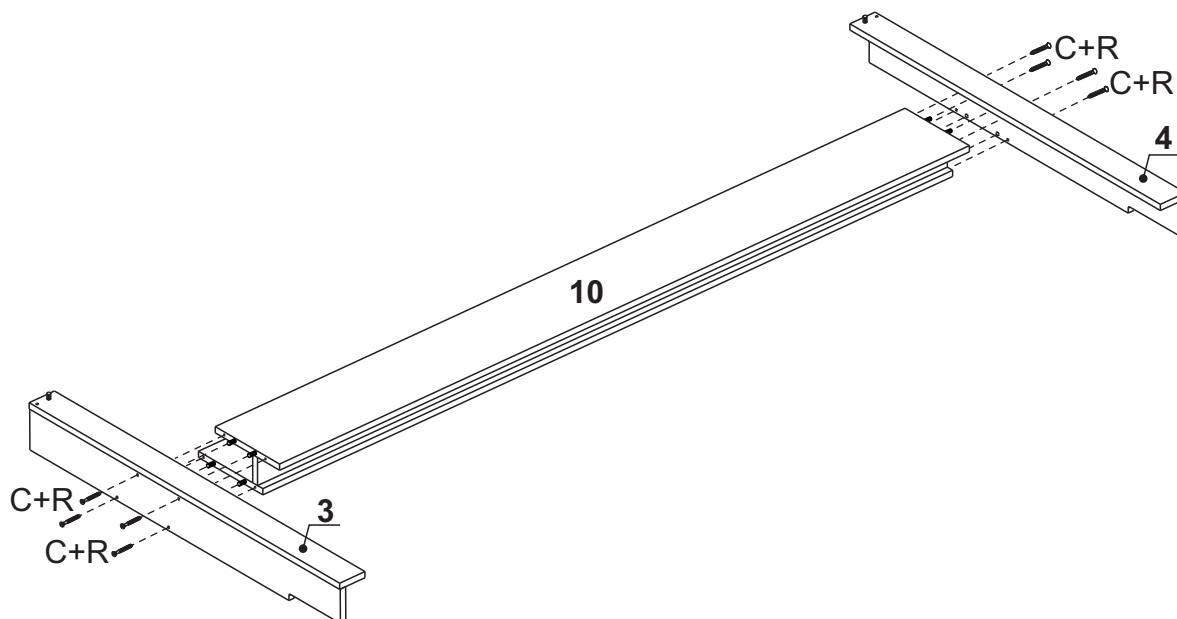

**Etapa 5/Paso 5/Step 5**

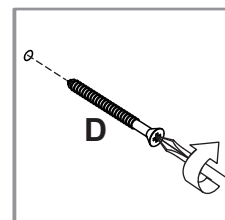
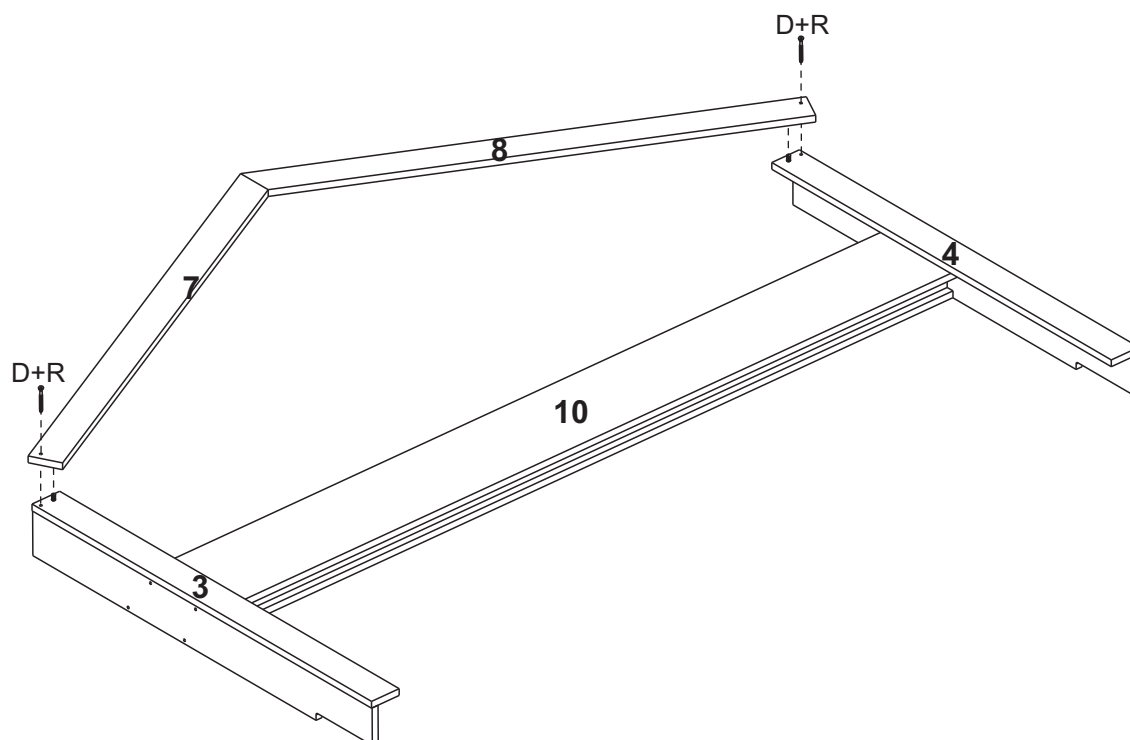

**Etapa 6/Paso 6/Step 6**

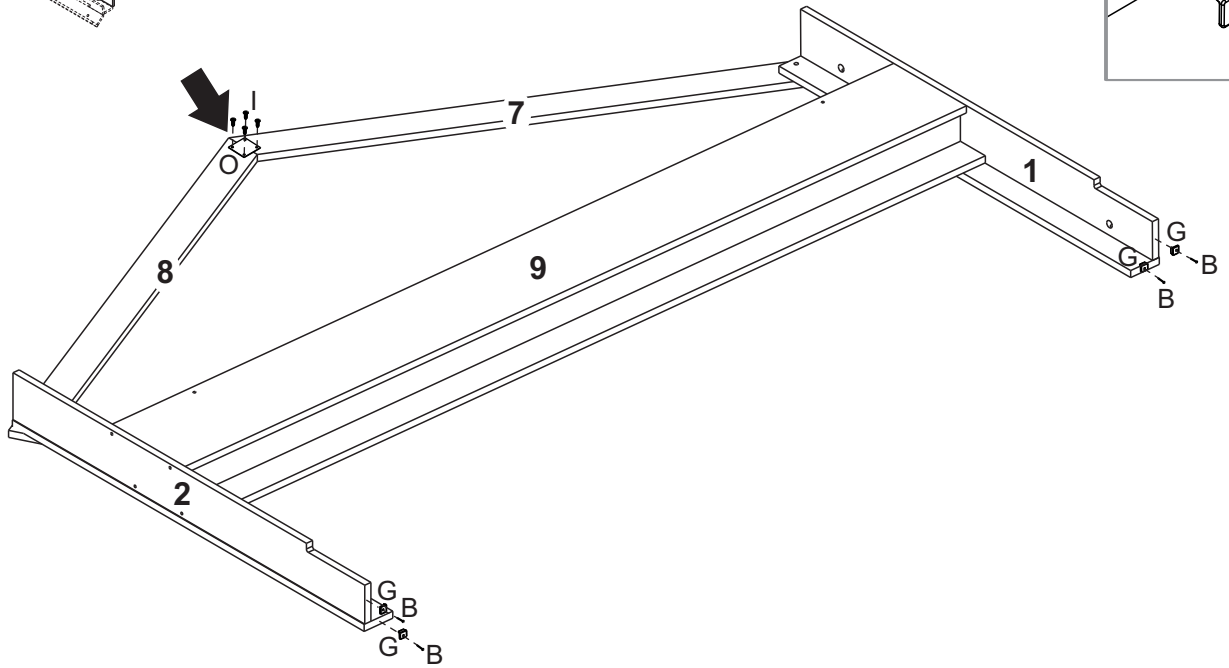
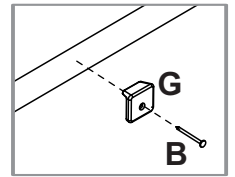
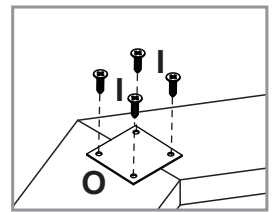
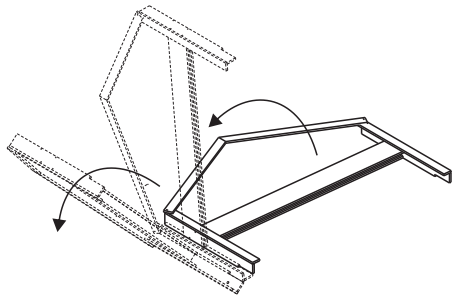

**Etapa 7/Paso 7/Step 7**

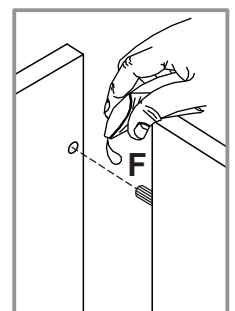
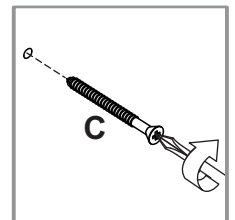
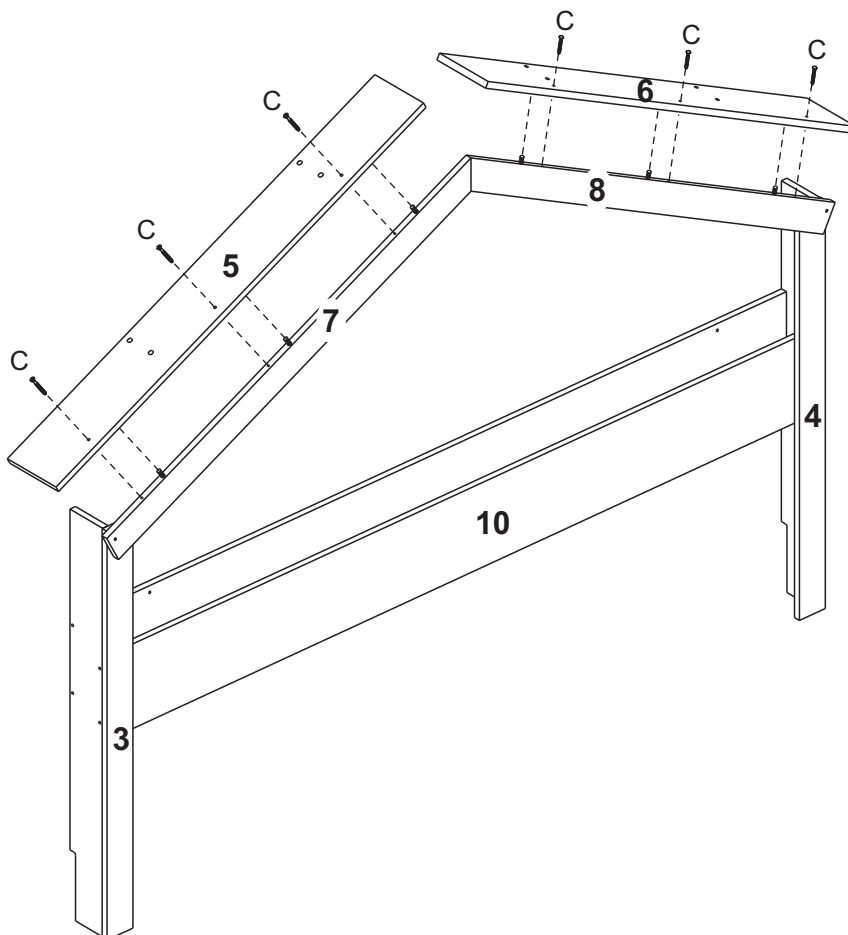

## Etapa 8/Paso 8/Step 8

Posicione o produto no local desejado.  
Em seguida, posicione as cantoneiras  
de fixação e marque na parede os  
pontos para furação.

*Coloque el producto en el lugar deseado.  
A continuación, coloque las escuadras  
de fijación y marque en la pared los puntos  
de perforación.*

*Position the product in the desired location.  
Then, position the mounting brackets  
and mark the drilling points on the wall.*

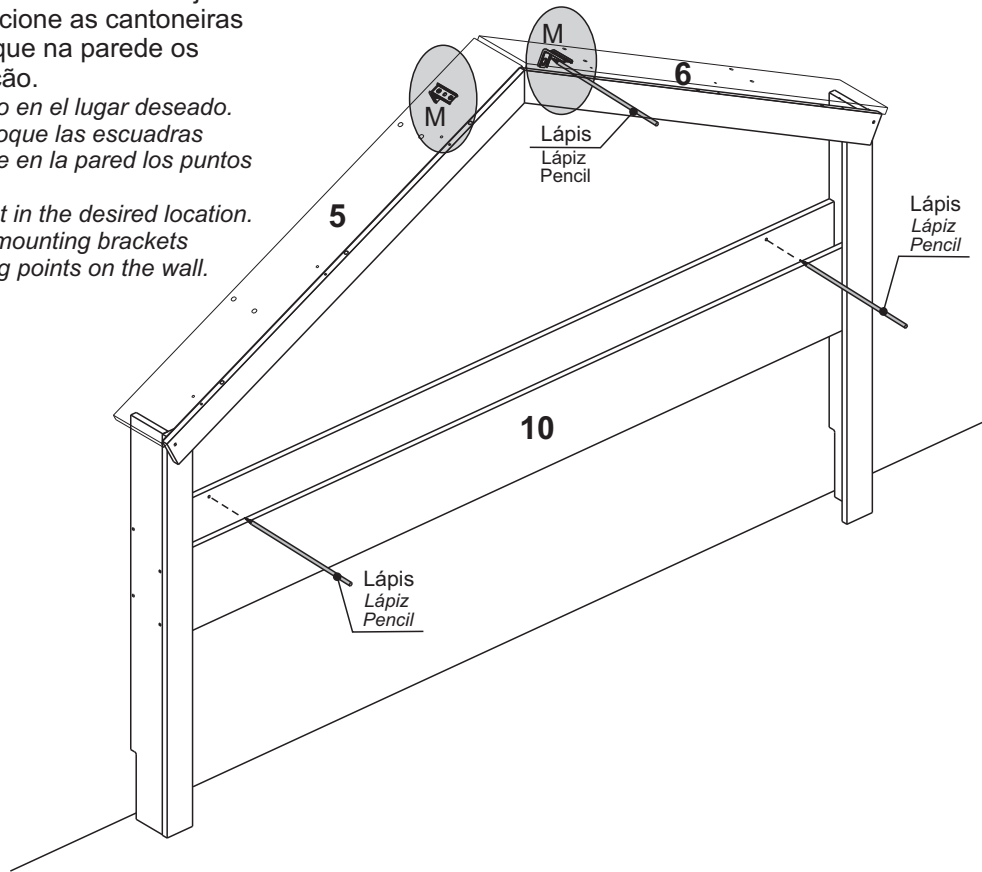

## Etapa 9/Paso 9/Step 9

Fixação na parede  
Fijación en la pared  
Wall mounting

1°

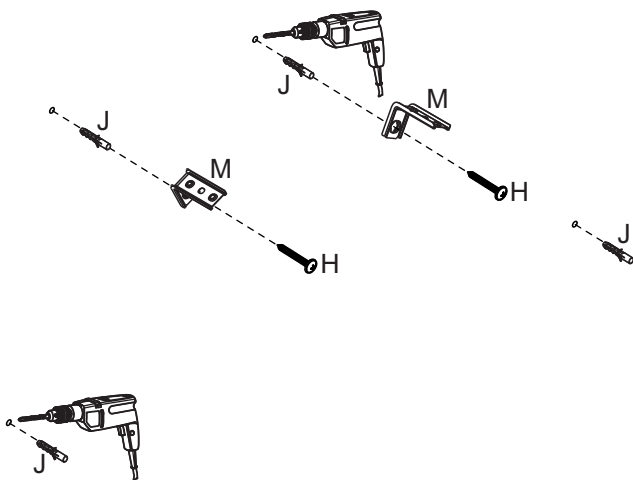

2°

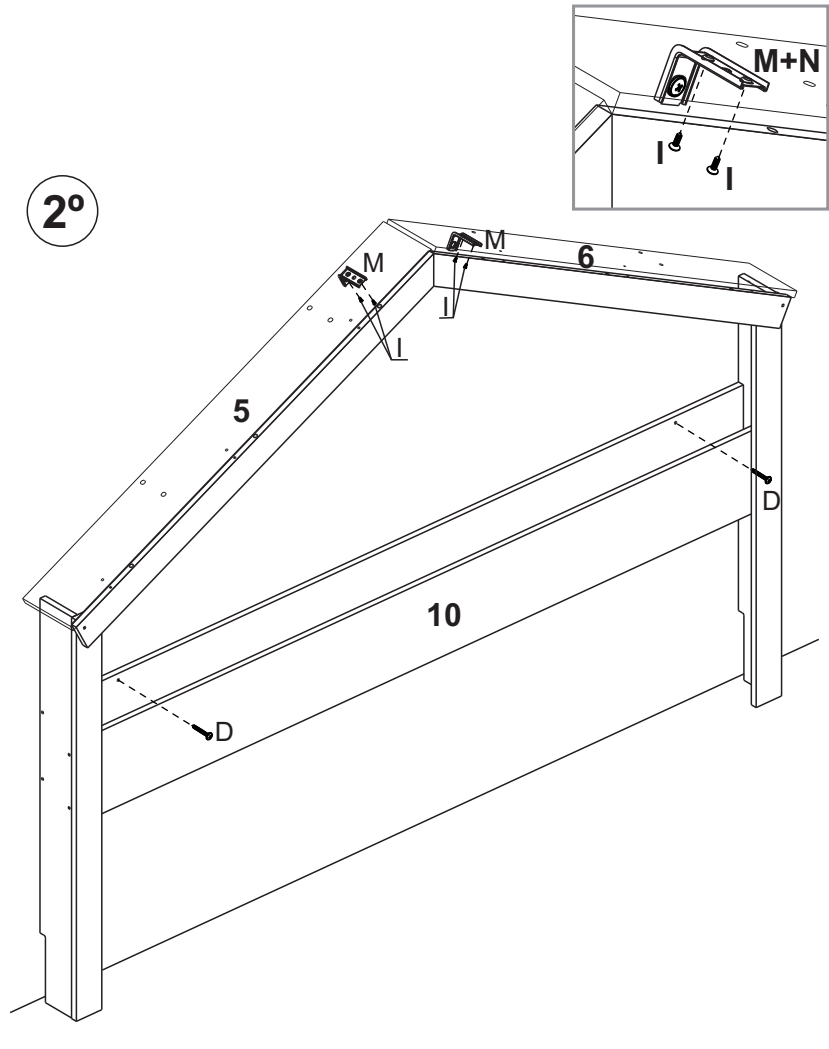

**Etapa 10/Paso 10/Step 10**

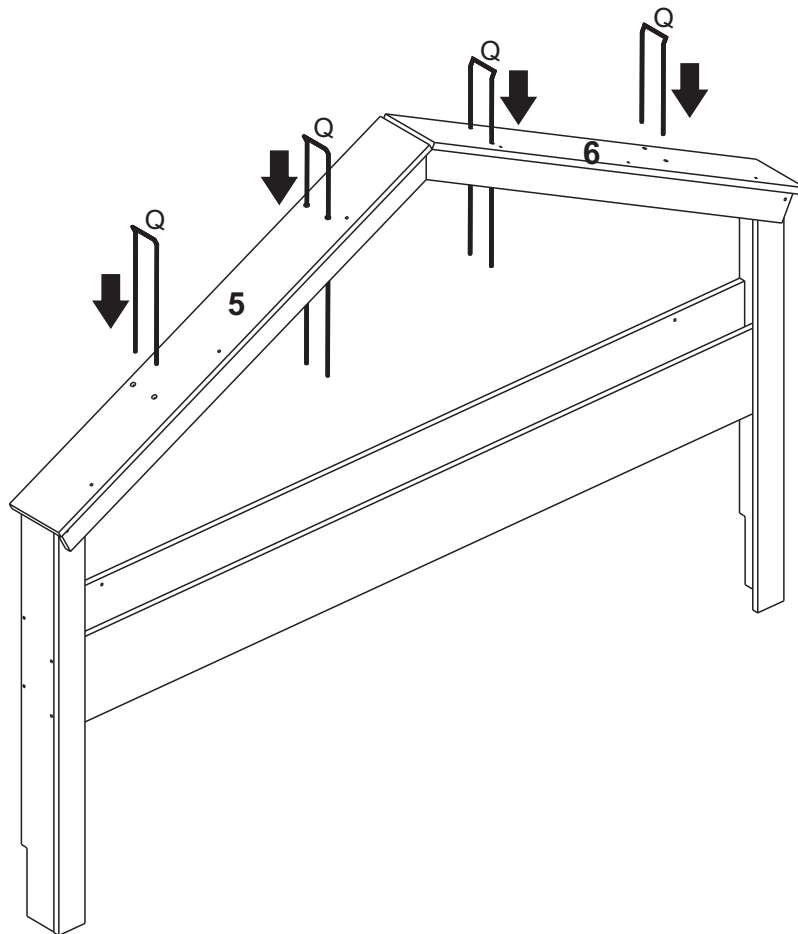

**Etapa 11/Paso 11/Step 11**

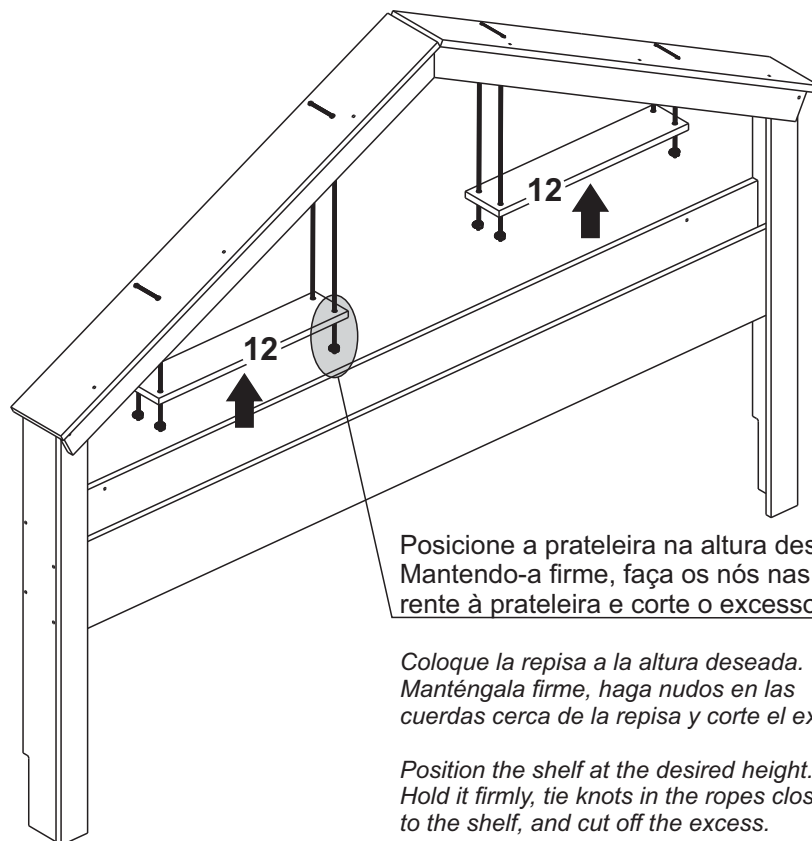

Posicione a prateleira na altura desejada. Mantendo-a firme, faça os nós nas cordas rente à prateleira e corte o excesso.

Coloque la repisa a la altura deseada. Manténgala firme, haga nudos en las cuerdas cerca de la repisa y corte el exceso.

Position the shelf at the desired height. Hold it firmly, tie knots in the ropes close to the shelf, and cut off the excess.