

Rev.: 00

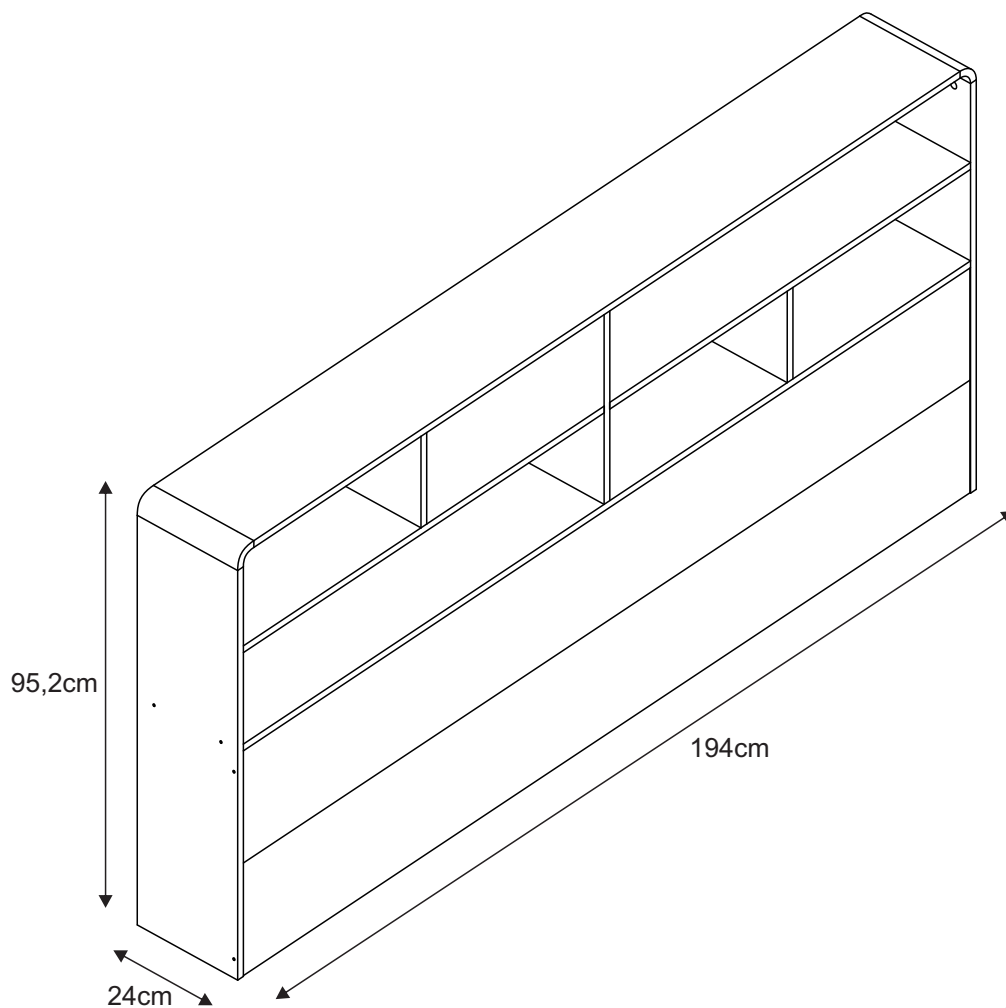

CV011



1 Pessoa
1 Persona



~~2 Pessoas~~
~~2 Personas~~



Tempo de Montagem
Tiempo de Armado

Abaixo as ferramentas, não fornecidas, mas necessárias para a montagem do produto.
Abajo las herramientas, no suministradas, pero necesarias para el montaje del producto.

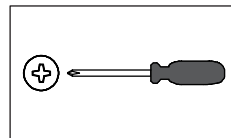
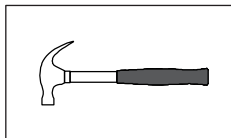

Furadeira com broca de 8mm
Taladro con broca de 8 mm

Parabéns!

Você acaba de adquirir um produto com a qualidade Completa Móveis.

Recomendações

- ⌘ Os parafusos devem ser apertados periodicamente.
- ⌘ Evitar batidas e o contato com objetos cortantes.

Manutenção e Limpeza

- ⌘ Use um pano levemente umedecido com água, seguido de pano seco.
- ⌘ Nunca utilize produtos químicos ou abrasivos.

Alguma dúvida? Fale com a gente.
Completa Ind. de Móveis Ltda
comercial@completamoveis.com.br

Felicitaciones!

Usted acaba de adquirir un producto con la calidad Completa Móveis.

Recomendaciones

- ⌘ Los tornillos deben ser ajustados periódicamente.
- ⌘ Evitar golpes y contacto con objetos cortantes.

Manutención y Limpieza

- ⌘ Utilice un paño ligeramente humedecido con agua, seguido de un paño seco.
- ⌘ Nunca utilice productos químicos o abrasivos.

Alguna duda? Hable con nosotros.
Completa Ind. de Móveis Ltda
comercial@completamoveis.com.br

IDENTIFICAÇÃO DAS PEÇAS/IDENTIFICACIÓN DE LAS PIEZAS

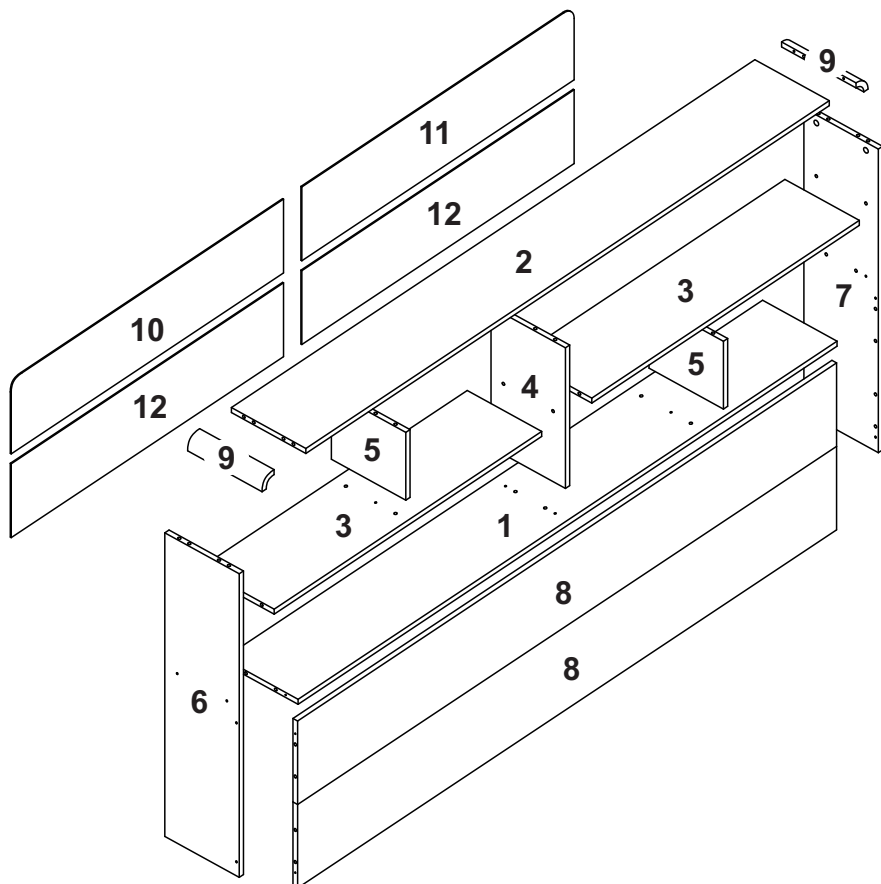

Nº	Descrição/Descripción	Medidas/ Dimensiones (mm)	Qtd./Cant.	Vol.
1	Base inferior/Base inferior	1910x240x15	01	01
2	Base superior/Base superior	1855x240x15	01	01
3	Prateleira/Repisa	948x240x15	02	01
4	Divisão maior/División mayor	421x240x15	01	01
5	Divisão menor/División menor	203x240x15	02	01
6	Lateral esquerda/Lateral izquierda	909x240x15	01	01
7	Lateral direita/Lateral derecha	909x240x15	01	01
8	Travessa/Travessaño	1910x250x15	02	01
9	Moldura curva/Pieza Curvada	240x42,5x42,5	02	01
10	Costa esquerda/Revés izquierdo	965x221x3	01	01
11	Costa direita/Revés derecha	965x221x3	01	01
12	Costa inferior/Revés inferior	965x221x3	02	01

Peso máximo recomendado. Deve ser distribuído uniformemente.
Peso máximo recomendado siendo este uniformemente distribuído.

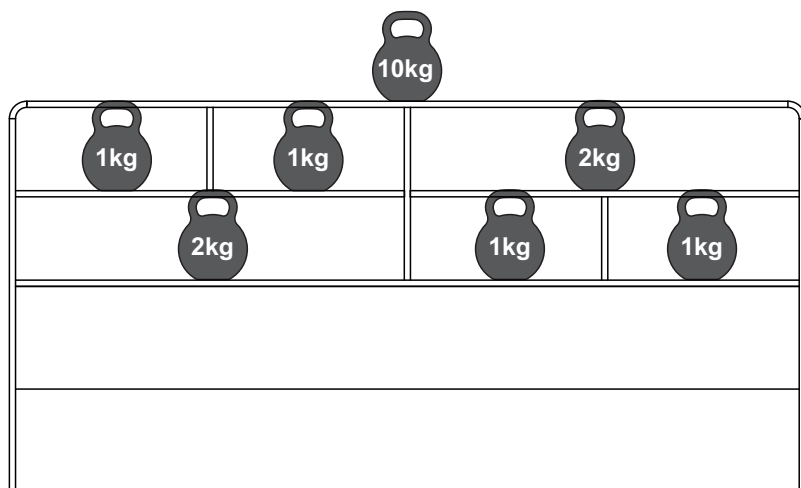

ACESSÓRIOS/ACCESORIOS

Antes de iniciar a montagem separe todos os acessórios. Em caso de dúvida no tamanho, utilize a régua no final da página.

Antes de empezar el armado, separe todos los accesorios. Si tienes dudas sobre el tamaño, utiliza la regla que se encuentra al final de la página.

ID	Desenho/Dibujo	Qtd./Cant.
A	Cavilha/Tarugo Ø8x30	36
B	Cavilha/Tarugo Ø8x50	02
C	Parafuso/Tornillo Ø4,0x14	14
D	Haste minifix/Tornillo minifix	13
E	Tambor minifix/Minifix	13
F	Parafuso/Tornillo Ø4,5x45	10
G	Bisnaga de cola/Tubo de pegamento	01
H	Prego/Clavo 10x10	63
I	Sapata Zapata	06
J	Parafuso/Tornillo Ø5,0x50	02
K	Cantoneira/Pieza L	02
L	Capa/Cubierta	02
M	Tapa furo PVC/Tapa agujero PVC 19mm	24
N	Bucha/Taco p/Tornillo 8mm	02
O	Garra metálica para costa Fijador para revés	10
P	Chapa metálica/Chapa metálica	04
Q	Cantoneira/Pieza L	01



PRÉ-MONTAGEM / PRE ARMADO

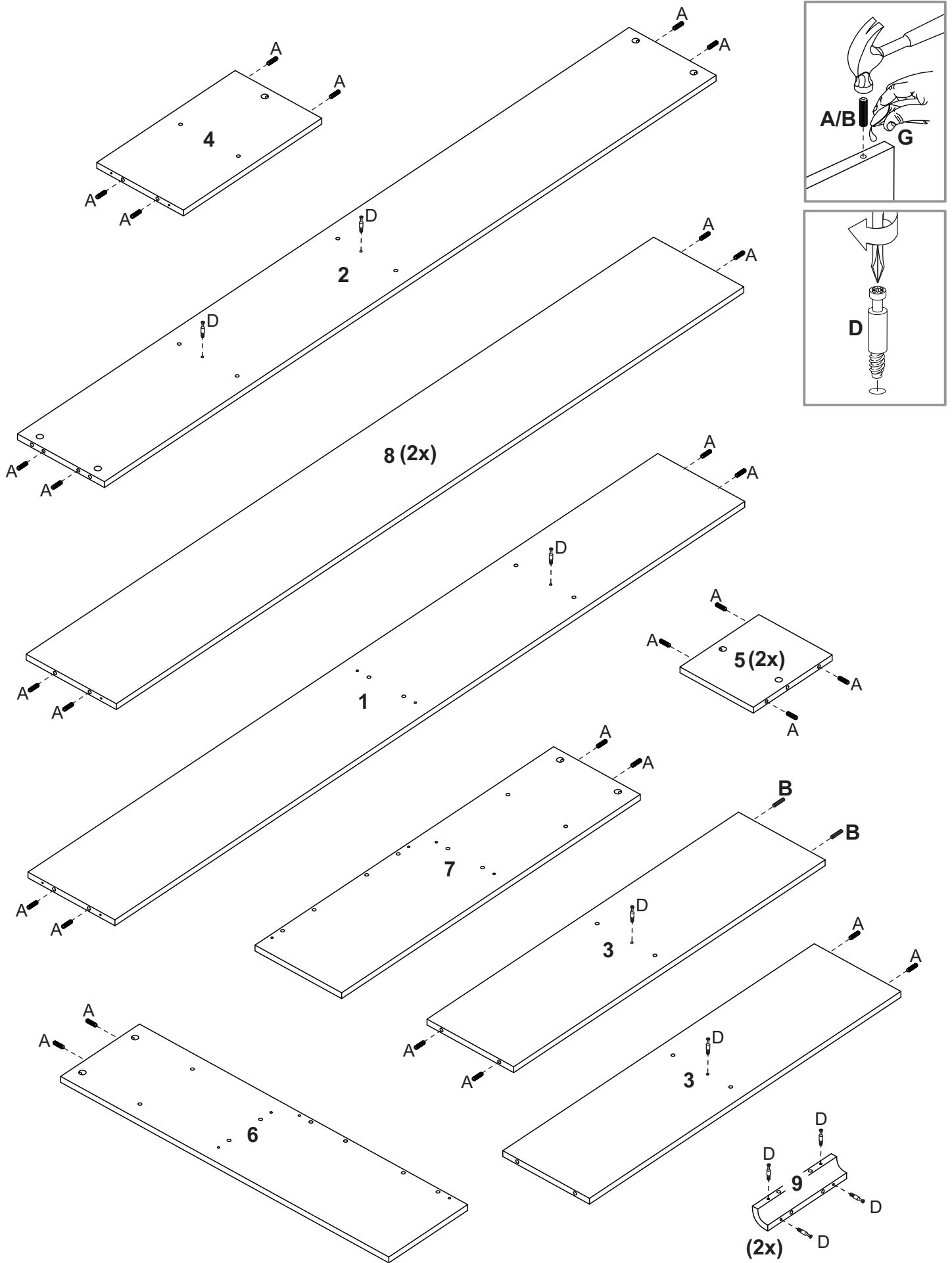

MONTAGEM / ARMADO

Etapa 1/Paso 1

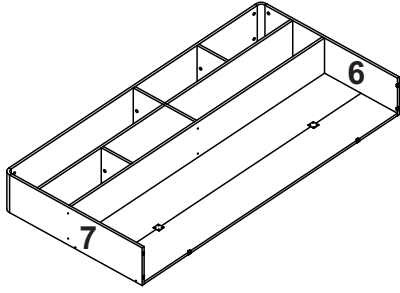

Posição da montagem
Posición de armado

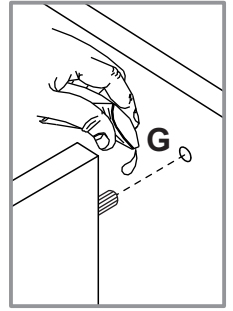
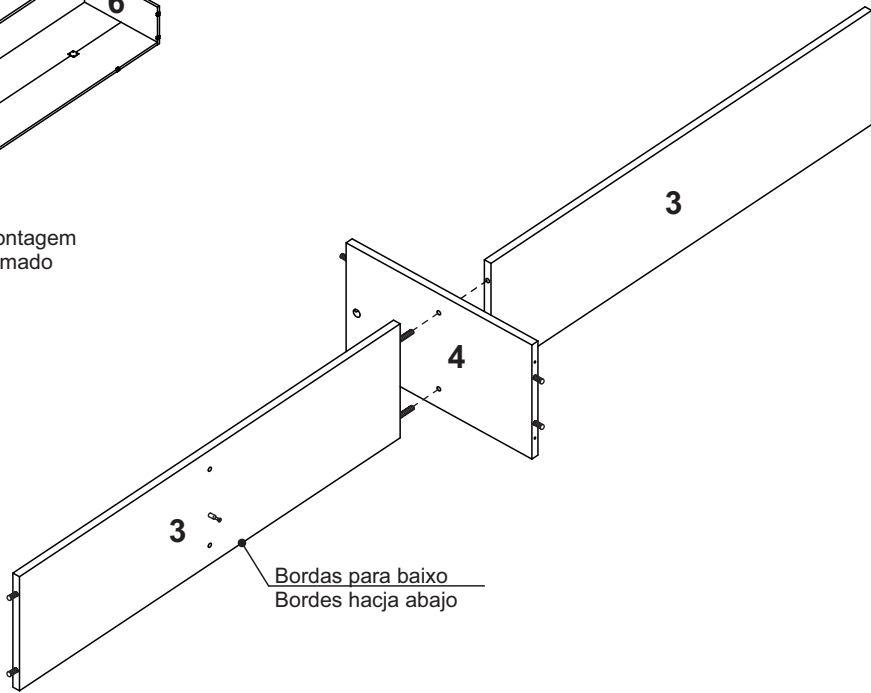

Etapa 2/Paso 2

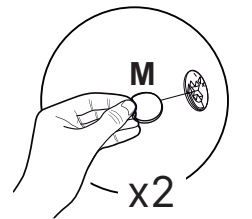
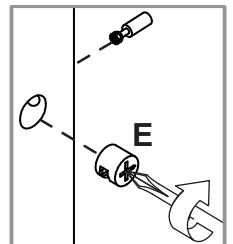
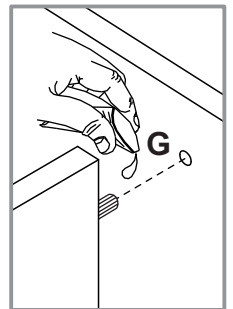
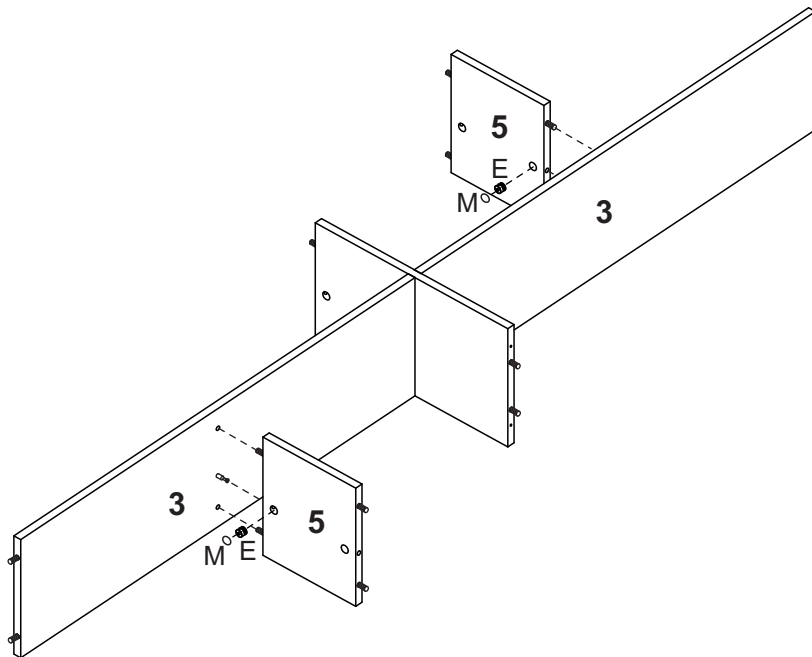

Etapa 3/Paso 3

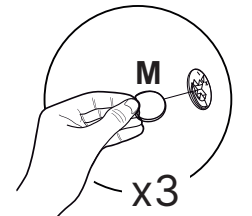
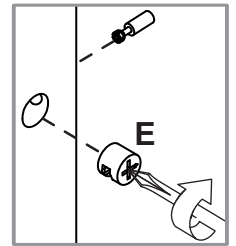
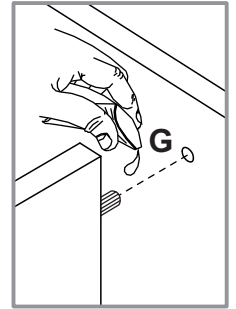
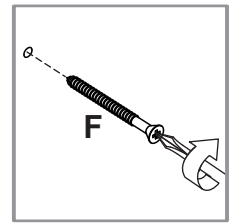
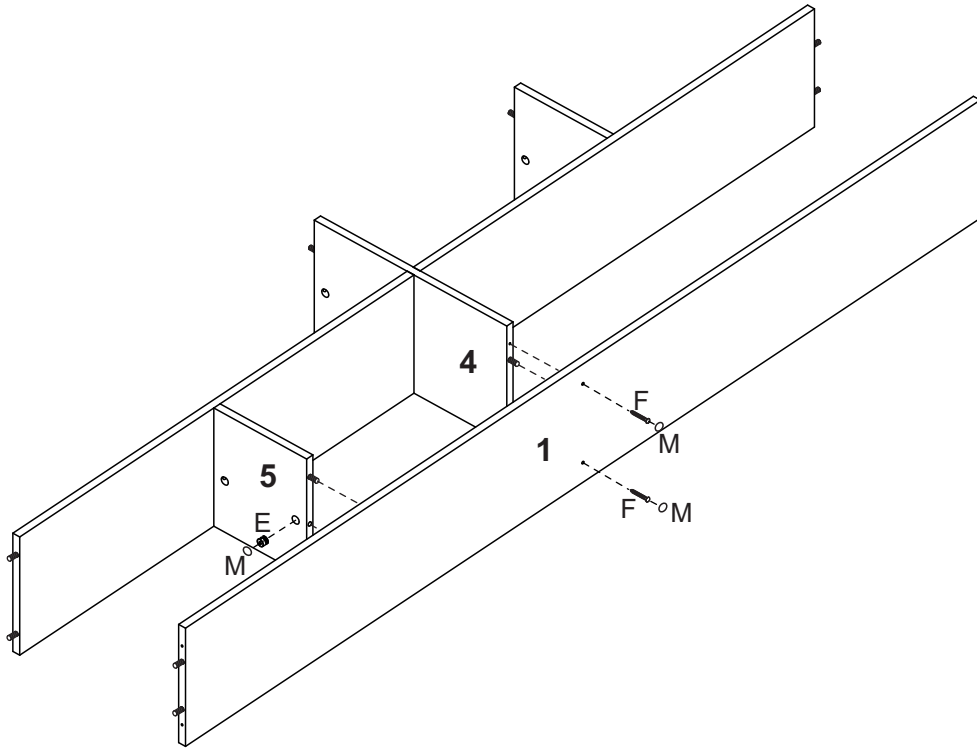

Etapa 4/Paso 4

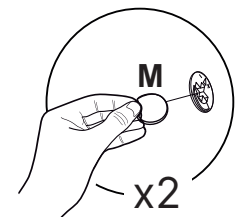
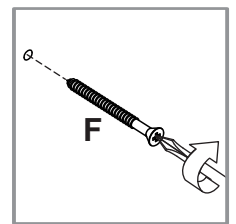
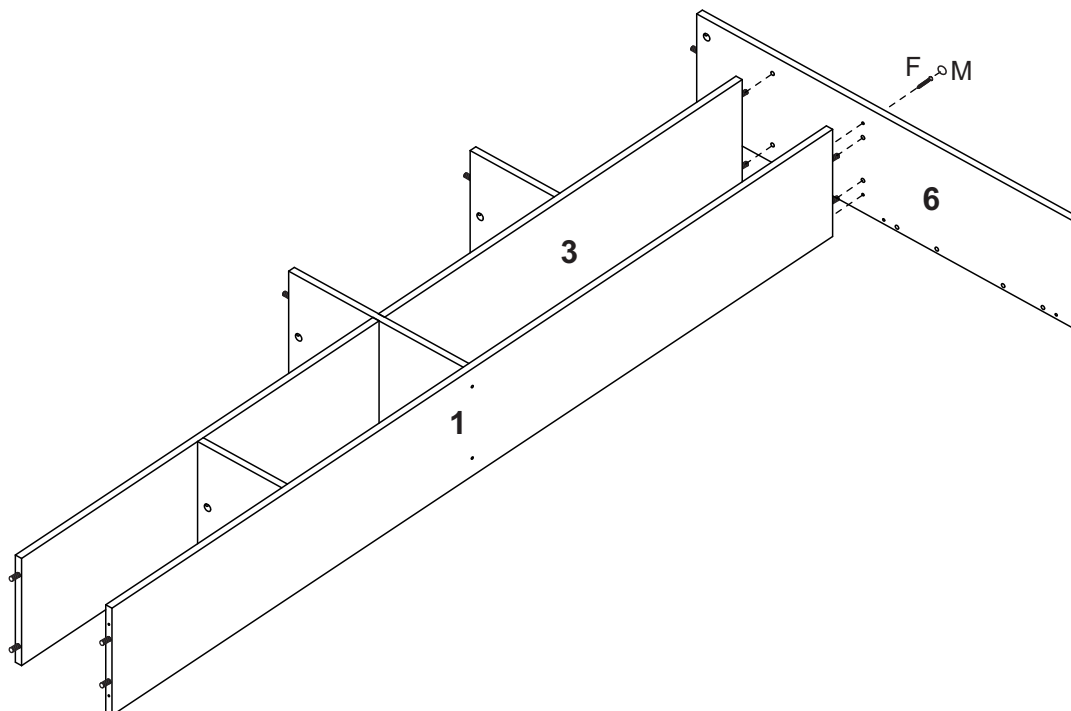

Etapa 5/Paso 5

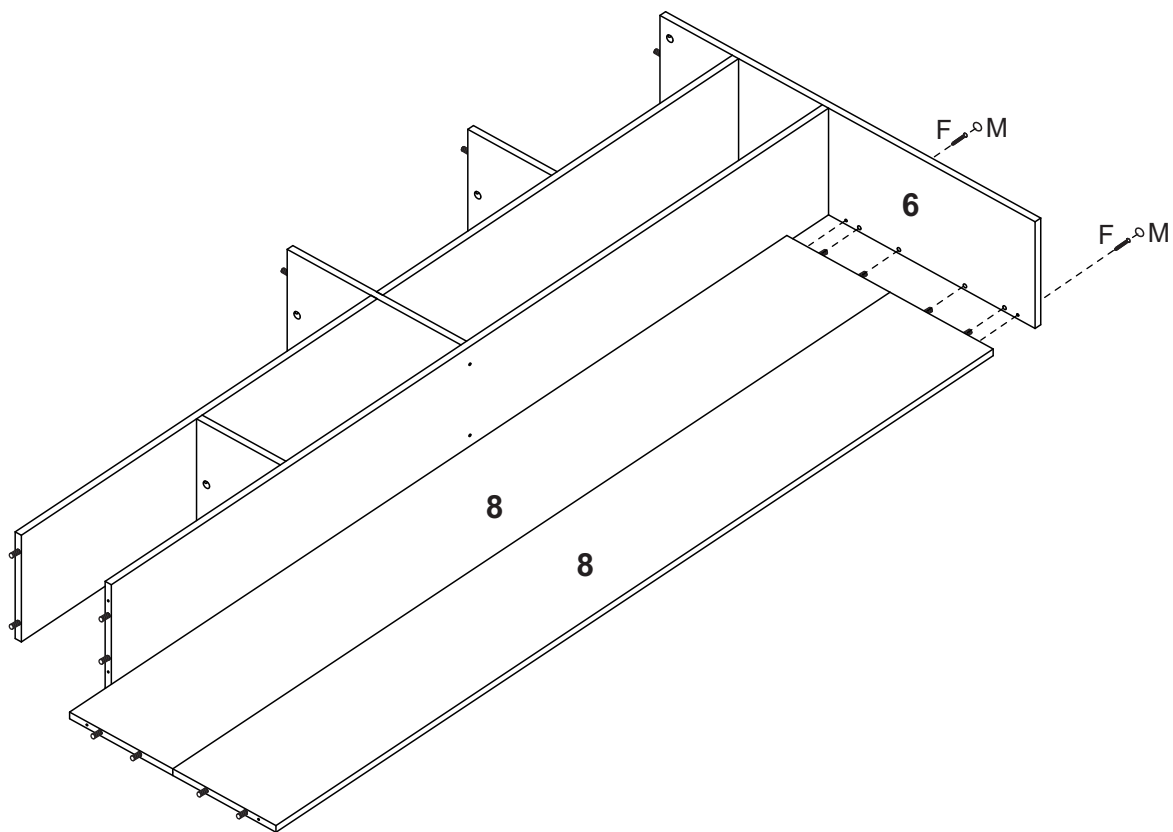

Etapa 6/Paso 6

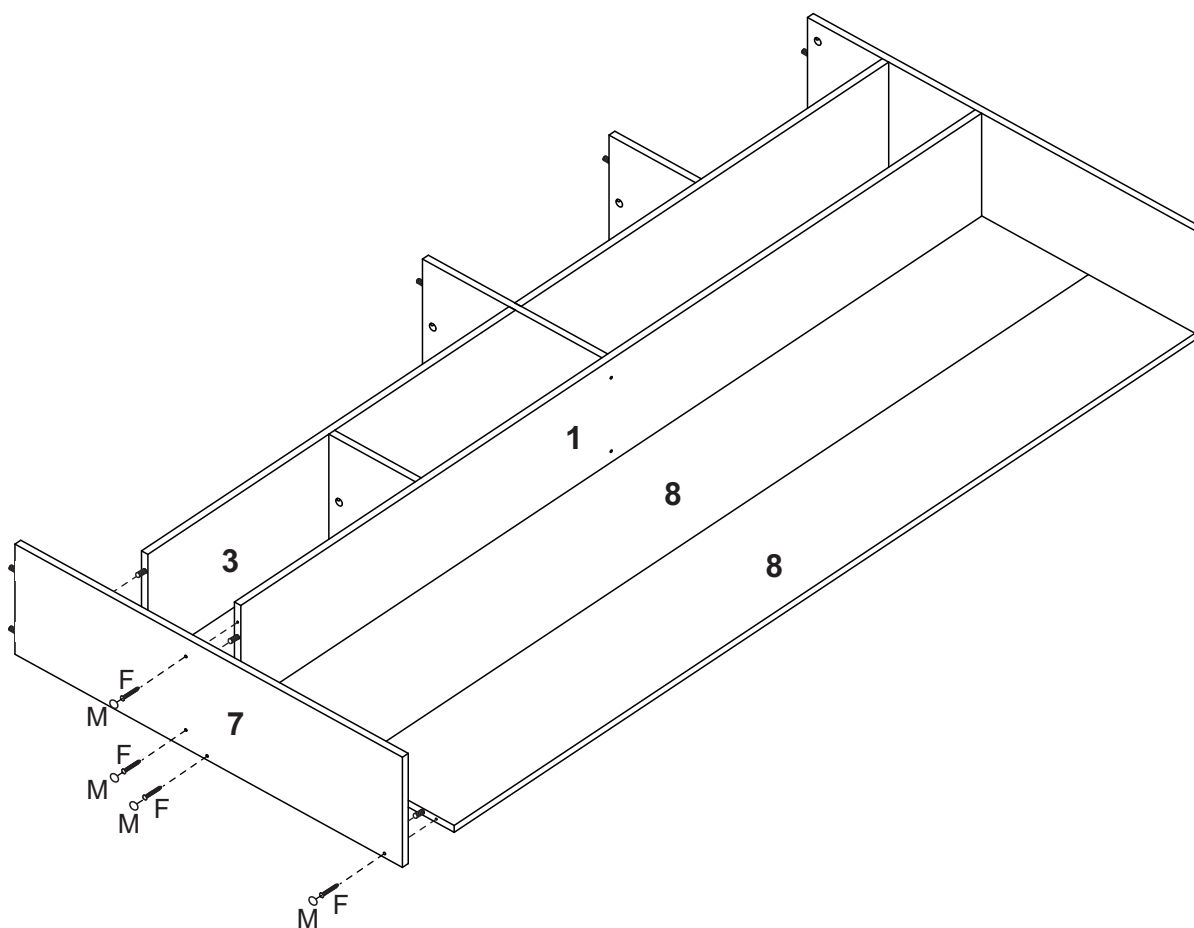

Etapa 7/Paso 7

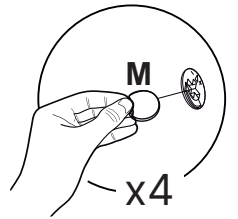
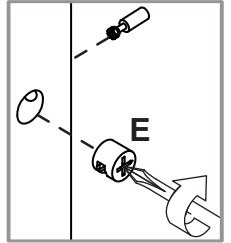
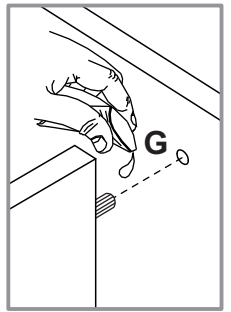
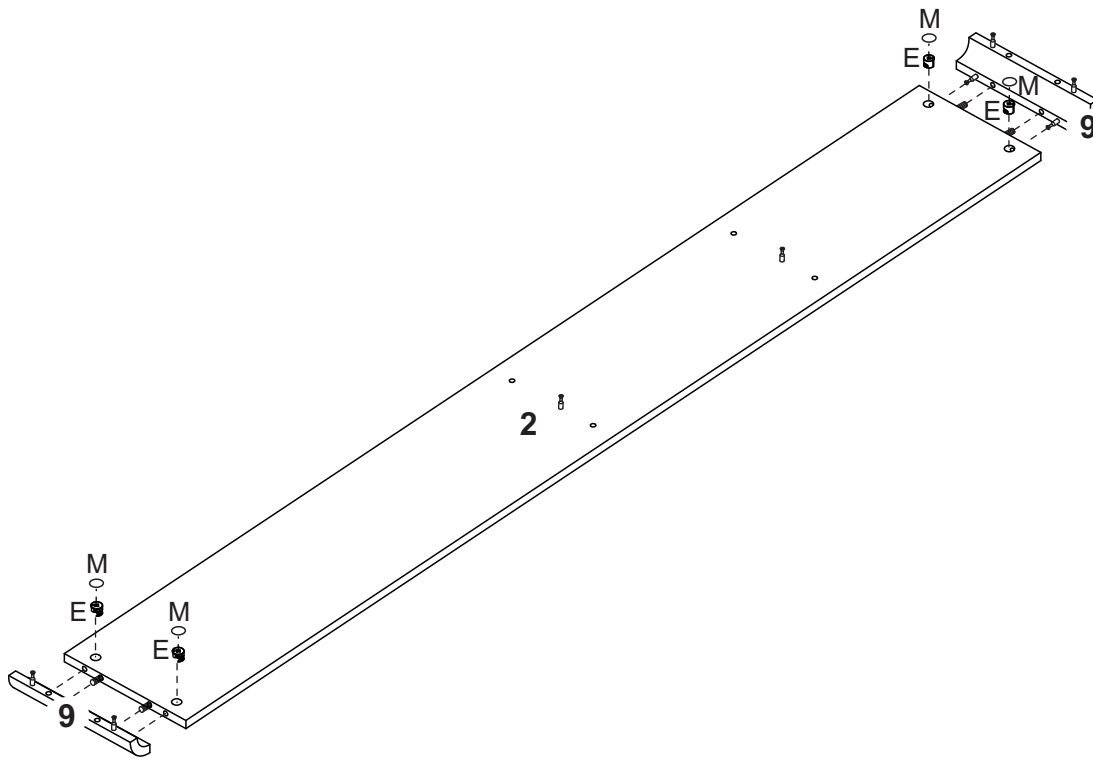

Etapa 8/Paso 8

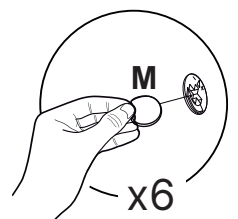
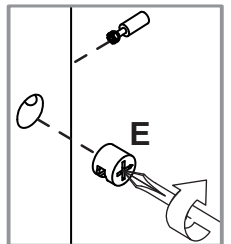
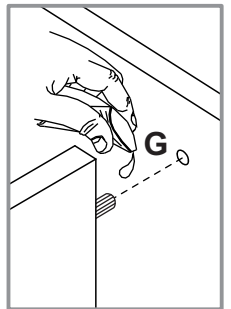
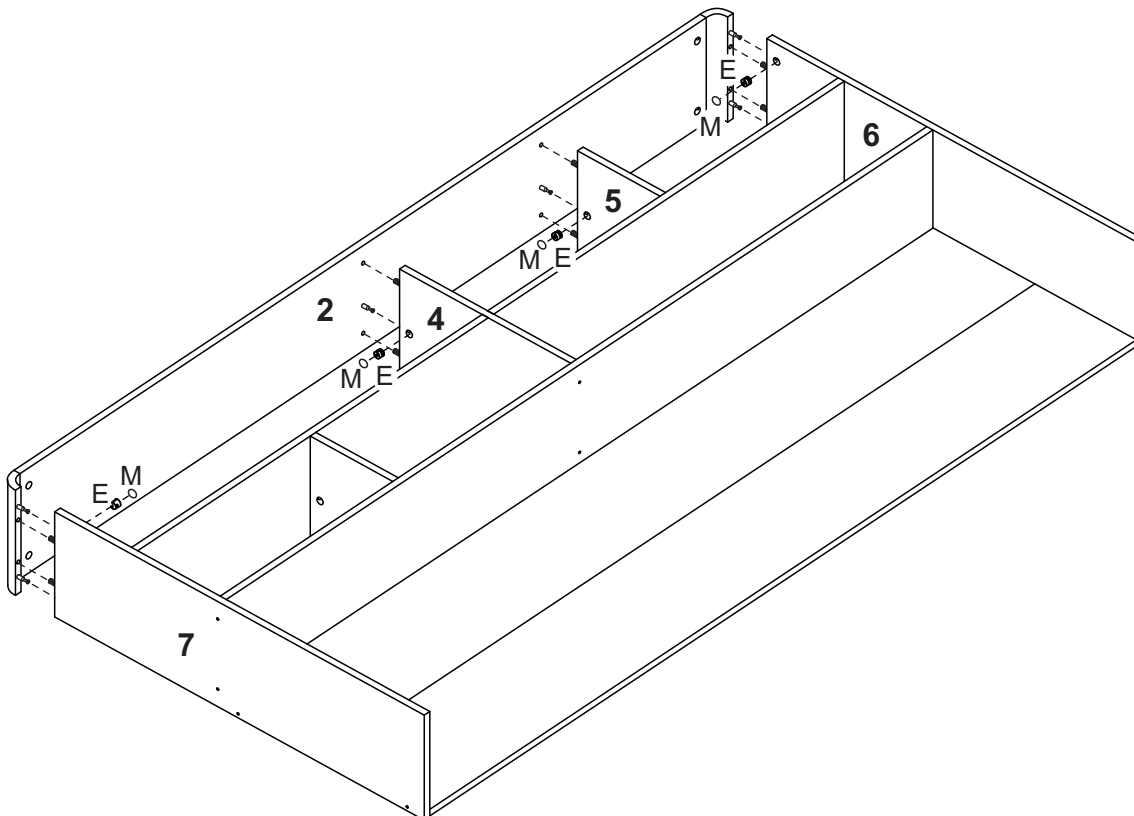

Etapa 9/Paso 9

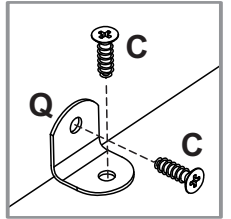
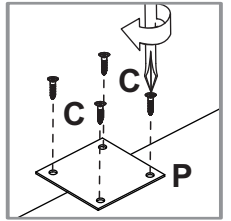
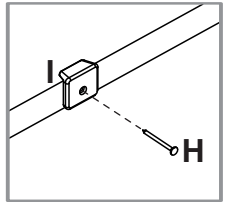
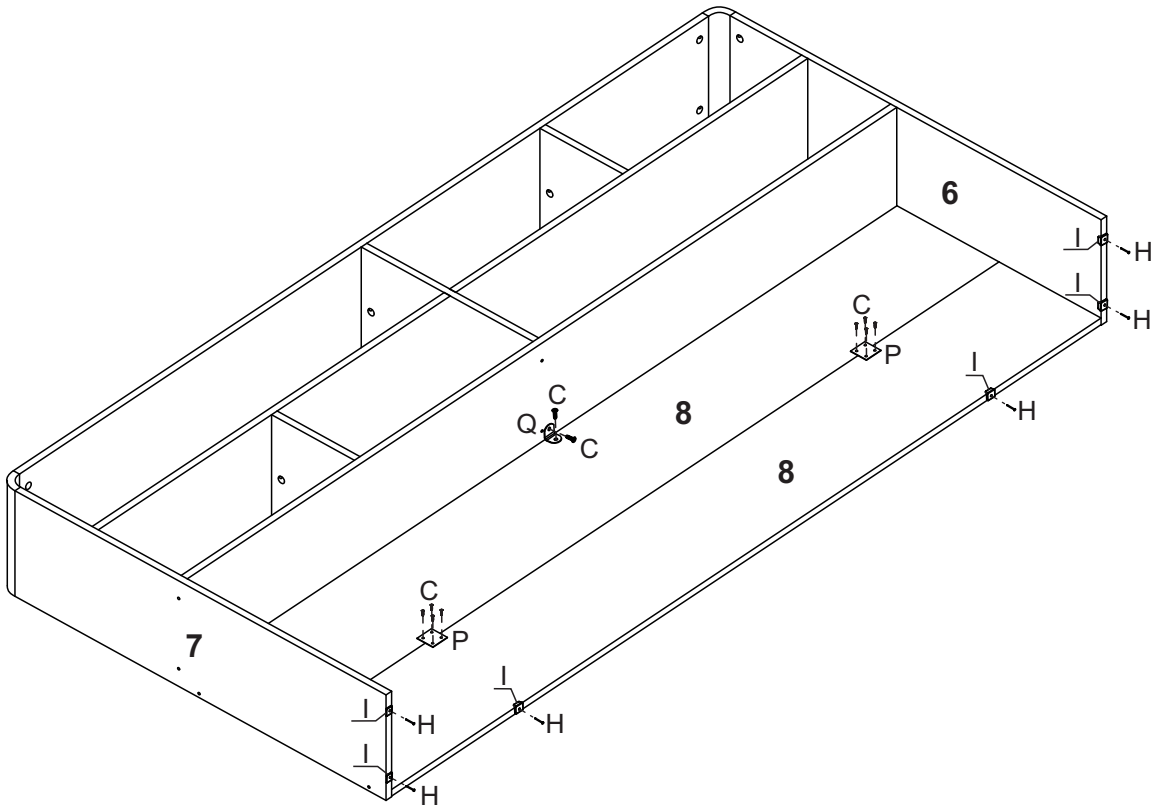

Etapa 10/Paso 10

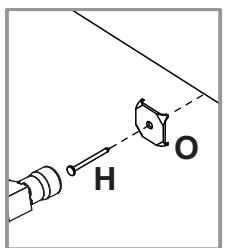
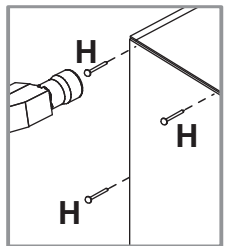
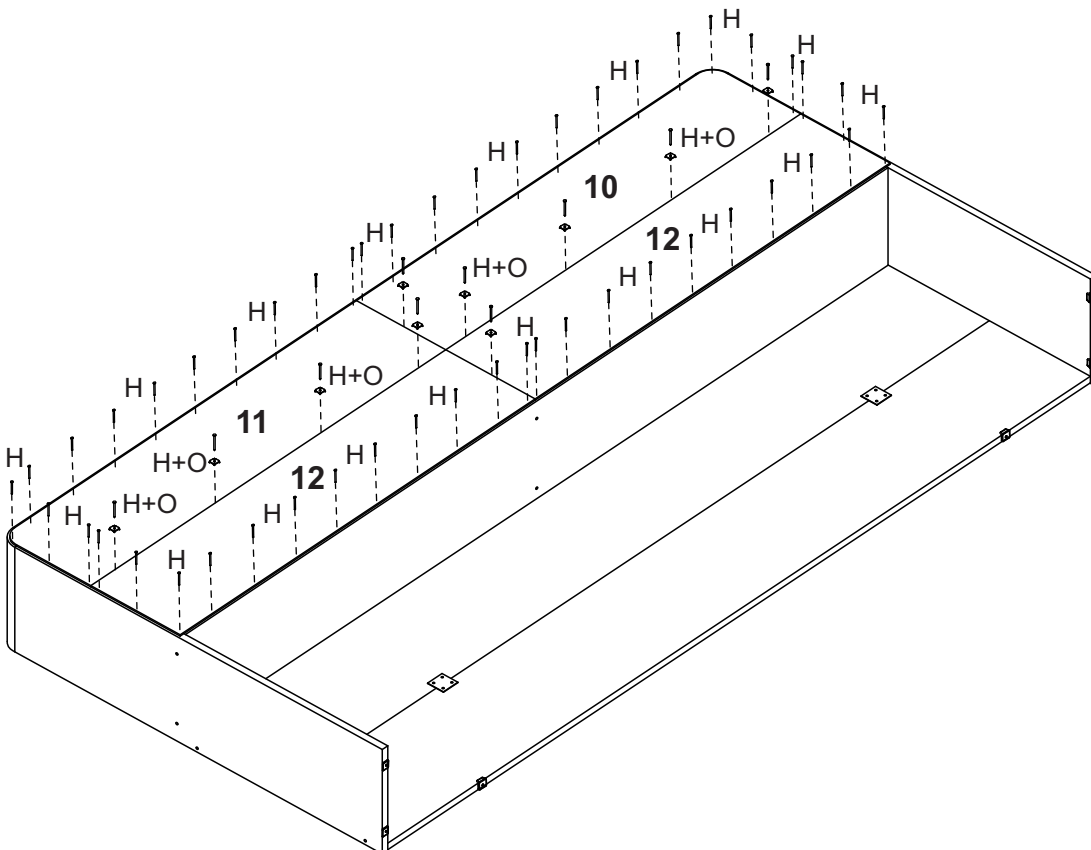

Etapa 11/Paso 11 Fixação na parede/Fijación en la pared

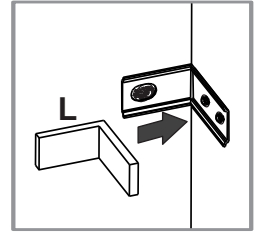
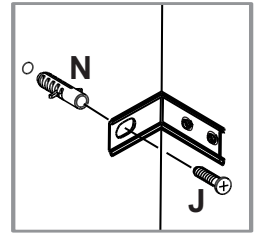
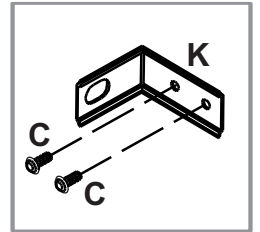
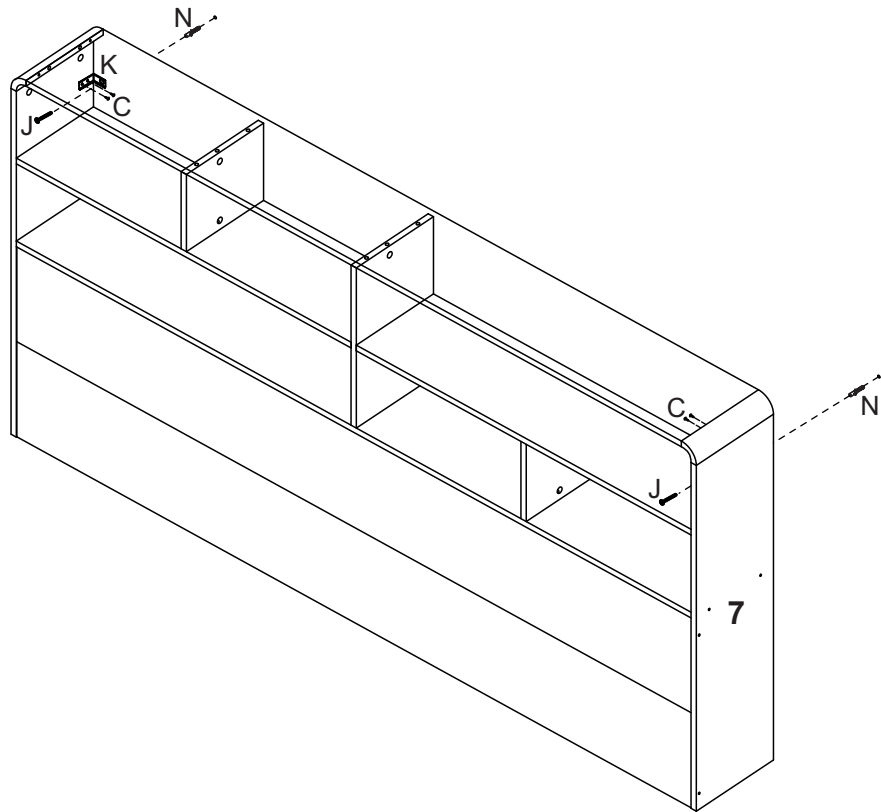

Etapa 12/Paso 12

